

Keysight DSOXT3NFC/ DSOX4NFC Near Field Communication Test Application

Notices

© Keysight Technologies, Inc. 2006-2016

No part of this manual may be reproduced in any form or by any means (including electronic storage and retrieval or translation into a foreign language) without prior agreement and written consent from Keysight Technologies, Inc. as governed by United States and international copyright laws.

Revision

Version 01.04.0000

Edition

July 15, 2016

Available in electronic format only

Published by:
Keysight Technologies, Inc.
1900 Garden of the Gods Road
Colorado Springs, CO 80907 USA

Warranty

The material contained in this document is provided "as is," and is subject to being changed, without notice, in future editions. Further, to the maximum extent permitted by applicable law, Keysight disclaims all warranties, either express or implied, with regard to this manual and any information contained herein, including but not limited to the implied warranties of merchantability and fitness for a particular purpose. Keysight shall not be liable for errors or for incidental or consequential damages in connection with the furnishing, use, or performance of this document or of any information contained herein. Should Keysight and the user have a separate written agreement with warranty terms covering the material in this document that conflict with these terms, the warranty terms in the separate agreement shall control.

Technology License

The hardware and/or software described in this document are furnished under a license and may be used or copied only in accordance with the terms of such license.

U.S. Government Rights

The Software is "commercial computer software," as defined by Federal Acquisition Regulation ("FAR") 2.101. Pursuant to FAR 12.212 and 27.405-3 and Department of Defense FAR Supplement ("DFARS") 227.7202, the U.S. government acquires commercial computer software under the same terms by which the software is customarily provided to the public. Accordingly, Keysight provides the Software to U.S. government customers under its standard commercial license, which is embodied in its End User License Agreement (EULA), a copy of which can be found at www.keysight.com/find/sweula. The license set forth in the EULA represents the exclusive authority by which the U.S. government may use, modify, distribute, or disclose the Software. The EULA and the license set forth therein, does not require or permit, among other things, that Keysight: (1) Furnish technical information related to commercial computer software or commercial computer software documentation that is not customarily provided to the public; or (2) Relinquish to, or otherwise provide, the government rights in excess of these rights customarily provided to the public to use, modify, reproduce, release, perform, display, or disclose commercial computer software or commercial computer software documentation. No additional government requirements beyond those set forth in the EULA shall apply, except to the extent that those terms, rights, or licenses are explicitly required from all providers of commercial computer software pursuant to the FAR and the DFARS and are set forth specifically in writing elsewhere in the EULA. Keysight shall be under no obligation to update, revise or otherwise modify the Software. With respect to any technical data as defined by FAR 2.101, pursuant to FAR 12.211 and 27.404.2 and DFARS 227.7102, the U.S. government acquires no greater than Limited Rights as defined in FAR 27.401 or DFAR 227.7103-5 (c), as applicable in any technical data.

Safety Notices

CAUTION

A **CAUTION** notice denotes a hazard. It calls attention to an operating procedure, practice, or the like that, if not correctly performed or adhered to, could result in damage to the product or loss of important data. Do not proceed beyond a **CAUTION** notice until the indicated conditions are fully understood and met.

WARNING

A **WARNING** notice denotes a hazard. It calls attention to an operating procedure, practice, or the like that, if not correctly performed or adhered to, could result in personal injury or death. Do not proceed beyond a **WARNING** notice until the indicated conditions are fully understood and met.

NFC Automated Testing—At a Glance

Keysight's Near Field Communication (NFC) Test Application software for Keysight InfiniiVision 3000T X-Series and 4000 X-Series oscilloscopes gives you a fast and easy way to verify and debug the physical layer characteristics of your NFC designs. This NFC test application software lets you automatically execute NFC conformance tests, and displays the results in a flexible report format. In addition to the measurement data, the report provides margin analysis that shows how closely your device passed or failed each test.

The PC-based NFC test application software controls a Keysight waveform generator to produce a variety of test signals based on various NFC standards, and then measures the response captured by a Keysight InfiniiVision X-Series oscilloscope with real-time sampling up to 5 GSa/s. Measurement results are then compared against published NFC specifications for pass/fail conditions.

The NFC Test Application guides you through the process of selecting and configuring tests, making oscilloscope connections, running tests, and evaluating the test results. This application:

- Lets you select individual or multiple tests to run.
- Shows you how to make connections to the test equipment and device under test based on selected connection type.
- Automatically checks for proper test equipment configuration.
- Automatically sets up the equipment for each test.
- Provides detailed information for each test that has been run and lets you specify the thresholds at which marginal or critical warnings appear.
- Creates a printable HTML report of the tests that have been run.

For more information, see:

- **Chapter 1**, "Prerequisites," starting on page 7
 - **"Required Equipment and Software"** on page 8
 - **"Installing the Required Software"** on page 14
 - **"Installing the NFC Triggering License on the Oscilloscope"** on page 15
 - **"Adding Instruments Using Keysight Connection Expert"** on page 16
- **Chapter 2**, "Using the Test Application," starting on page 21
 - **"Starting the NFC Test Application"** on page 22
 - **"Creating or Opening a Test Project"** on page 24
 - **"Setting Up the Test Environment"** on page 25
 - **"Selecting Tests"** on page 29
 - **"Configuring Tests"** on page 31
 - **"Connecting the Test Equipment"** on page 33
 - **"Running Tests"** on page 38
 - **"Automating the Application"** on page 48

- ["Viewing Results"](#) on page 53
- ["Viewing/Exporting/Printing the Report"](#) on page 59
- ["Saving Test Projects"](#) on page 64
- ["Controlling the Application via a Remote PC"](#) on page 65
- [Chapter 3](#), "About the Tests," starting on page 69
- [Chapter 4](#), "Manufacturing Mode Integration," starting on page 73

For a printable version of this help file, see: [NFC Automated Testing Online Help](#).

- See Also
- [Keysight DSOXT3NFC/DSOX4NFC Automated NFC Test Software Data Sheet](#)

Contents

NFC Automated Testing—At a Glance / 3

1 Prerequisites

Required Equipment and Software / 8

Keysight 3-in-1 Programmable NFC Antenna / 9

TCI-II Programmable NFC Antenna / 12

Installing the Required Software / 14

Installing the Keysight IO Libraries Suite / 14

Installing the NFC Test Application software / 14

Installing the NFC Triggering License on the Oscilloscope / 15

Adding Instruments Using Keysight Connection Expert / 16

2 Using the Test Application

Starting the NFC Test Application / 22

Creating or Opening a Test Project / 24

To set load preferences / 24

Setting Up the Test Environment / 25

Selecting Tests / 29

Configuring Tests / 31

Connecting the Test Equipment / 33

Connections for a Keysight 3-in-1 Antenna / 34

Connections for a TCI-II Antenna / 35

Connections for a Reference Poller Antenna / 36

Connections for a Reference Listener Antenna / 37

Running Tests / 38

To select the "store mode" / 40

To run multiple times / 41

To send email on pauses or stops / 43

To pause or stop on events / 43

To specify the event / 45

To set the display preferences / 45

To set the run preferences / 47

- Automating the Application / 48
 - To enter commands in Script mode / 48
 - To enter commands in Files mode / 50
 - To begin Script or Files execution / 51
 - To display automation settings status / 51
 - To try a command line / 51
- Viewing Results / 53
 - To change margin thresholds / 54
 - To set test display preferences / 55
 - To set trial display preferences / 55
 - To select jump actions / 56
 - To debug individual test failures with the oscilloscope / 57
- Viewing/Exporting/Printing the Report / 59
 - To export the report / 61
 - To print the report / 63
- Saving Test Projects / 64
 - To set AutoRecovery preferences / 64
- Controlling the Application via a Remote PC / 65
 - To identify the remote interface version / 65
 - To enable the remote interface / 66
 - To enable remote interface hints / 67

3 About the Tests

4 Manufacturing Mode Integration

Index

1 Prerequisites

Required Equipment and Software / 8

Installing the Required Software / 14

Installing the NFC Triggering License on the Oscilloscope / 15

Adding Instruments Using Keysight Connection Expert / 16

Before running the automated tests, you need to acquire the required equipment and software, and you should calibrate the oscilloscope. After the oscilloscope has been calibrated, you are ready to start the NFC Test Application and perform measurements.

Required Equipment and Software

In order to run the NFC automated tests, you need the following equipment and software:

- One of these InfiniiVision X-Series oscilloscopes with the NFC Triggering license:
 - 3000T X-Series oscilloscope with the DSOXT3NFC license.
 - 4000 X-Series oscilloscope with the DSOX4NFC license.
- A two-channel Keysight Trueform 33500 Series or 33600 Series waveform generator to provide a variety of test signals based on various NFC standards.

Please refer to the datasheet for the latest list of supported oscilloscopes and waveform generators.

- An NFC antenna. The NFC test application supports these types of antennas:
 - Keysight 3-in-1 Programmable NFC Antenna

This is the 3-in-1 antenna provided by Keysight. It integrates poller, listener, and resonant frequency test coil antennas into one printed-circuit board. With this multi-coil programmable antenna, testing can quickly progress from Listener mode to Poller mode to resonant frequency testing without having to physically move the DUT from one antenna type to the next. There are three versions of the Keysight 3-in-1 antenna:

- N2116A 3-in-1 programmable NFC antenna, 5 mm spacing between poller/listener coils
- N2134A 3-in-1 programmable NFC antenna, 10 mm spacing between poller/listener coils
- N2135A 3-in-1 programmable NFC antenna, 15 mm spacing between poller/listener coils

For more information, see **“Keysight 3-in-1 Programmable NFC Antenna”** on page 9.

- Keysight TCI-II Programmable NFC Antenna (Test Coil Interface - version 2)

This is the 2-in-1 antenna provided by Keysight. It integrates both poller and listener antennas into one printed-circuit board. With this multi-coil programmable antenna, testing can quickly progress from Listener mode to Poller mode without having to physically move the DUT from one antenna type to the next. The size of the coil is equivalent to Poller-3 and Listener-3 coil size. For more information, see **“TCI-II Programmable NFC Antenna”** on page 12.

- Reference Antennas (Poller and Listener)

These are the reference antennas specified by the NFC Forum. There are a total of 6 reference antennas available: Poller-0, Poller-3, Poller-6, Listener-1, Listener-3, Listener-6. The coil of the antenna get smaller with increasing number.

- A user-supplied controller PC with the Windows 7 operating system.
The controller PC requires the following software (installed in this order):
 - a Keysight I/O Libraries version 17.2 or greater.
 - b .NET Framework 4.5.2.
 - c MATLAB Compiler Runtime 7.15.
 - d NFC Test Application software.
 See **“Installing the Required Software”** on page 14.
- The NFC device under test.

Keysight 3-in-1 Programmable NFC Antenna



The Keysight 3-in-1 programmable NFC multi-coil antenna includes a Poller 3 and Listener 3 equivalent test antenna that can be quickly switched between various test modes for fast test throughput. The following shows a block diagram of the Keysight N2116A, N2134A, and N2135A 3-in-1 programmable NFC antennas.

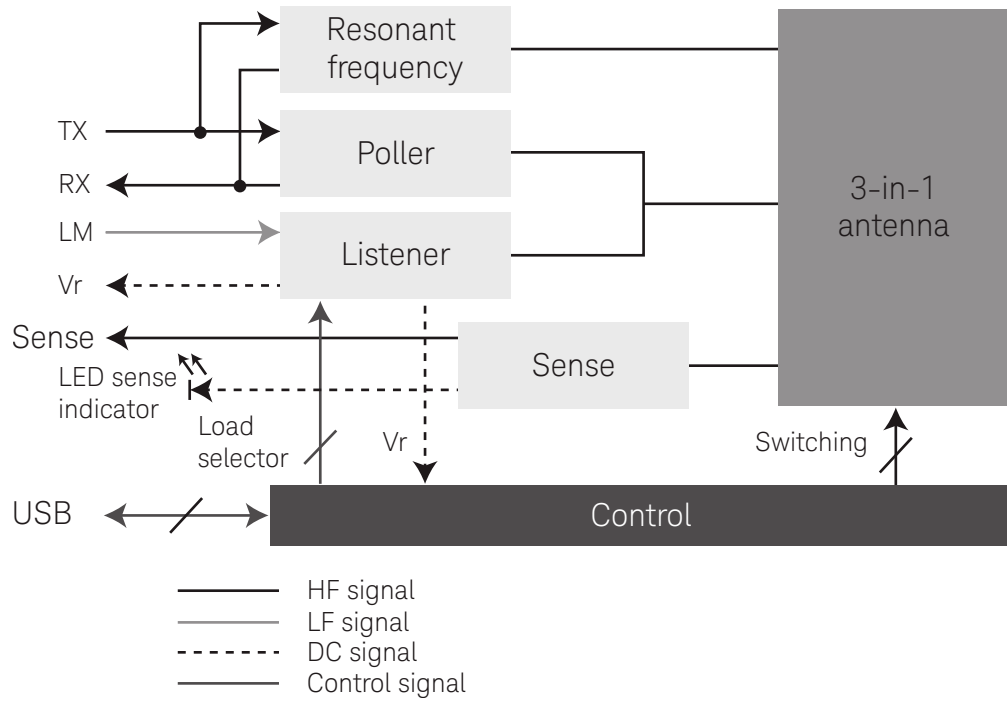

If you are creating a holding fixture for one of the Keysight 3-in-1 antennas and your device under test, see:

- [“N2116A 3-in-1 Programmable NFC Antenna Dimensions”](#) on page 10
- [“N2134A 3-in-1 Programmable NFC Antenna Dimensions”](#) on page 11
- [“N2135A 3-in-1 Programmable NFC Antenna Dimensions”](#) on page 12

N2116A 3-in-1 Programmable NFC Antenna Dimensions

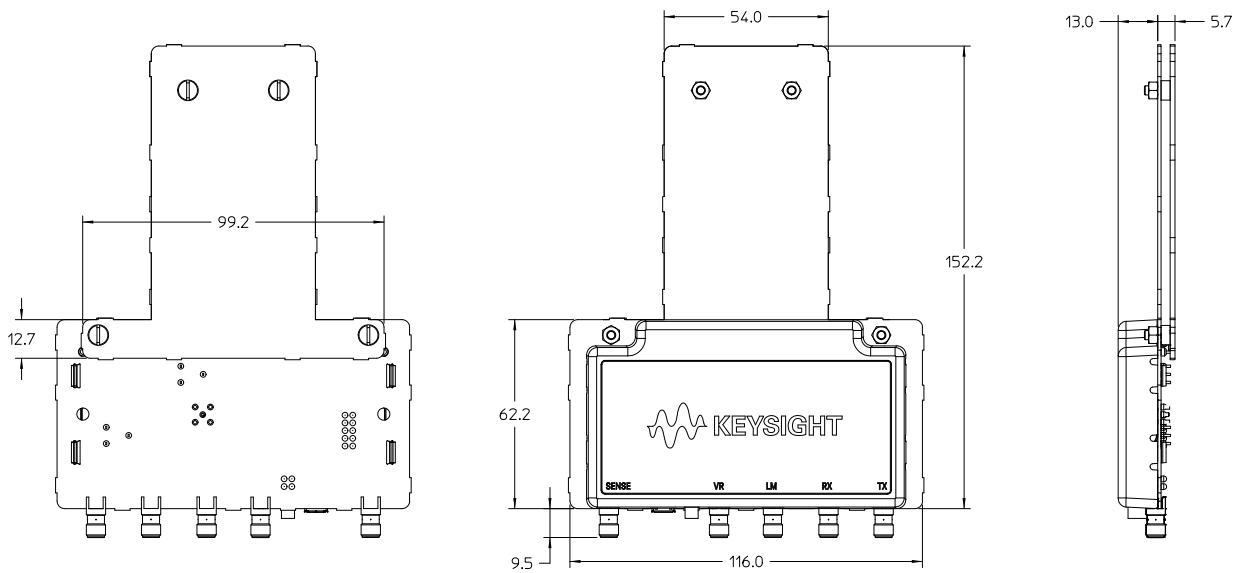

The N2116A 3-in-1 programmable NFC antenna provides 5 mm spacing between poller/listener coils.

N2134A 3-in-1 Programmable NFC Antenna Dimensions

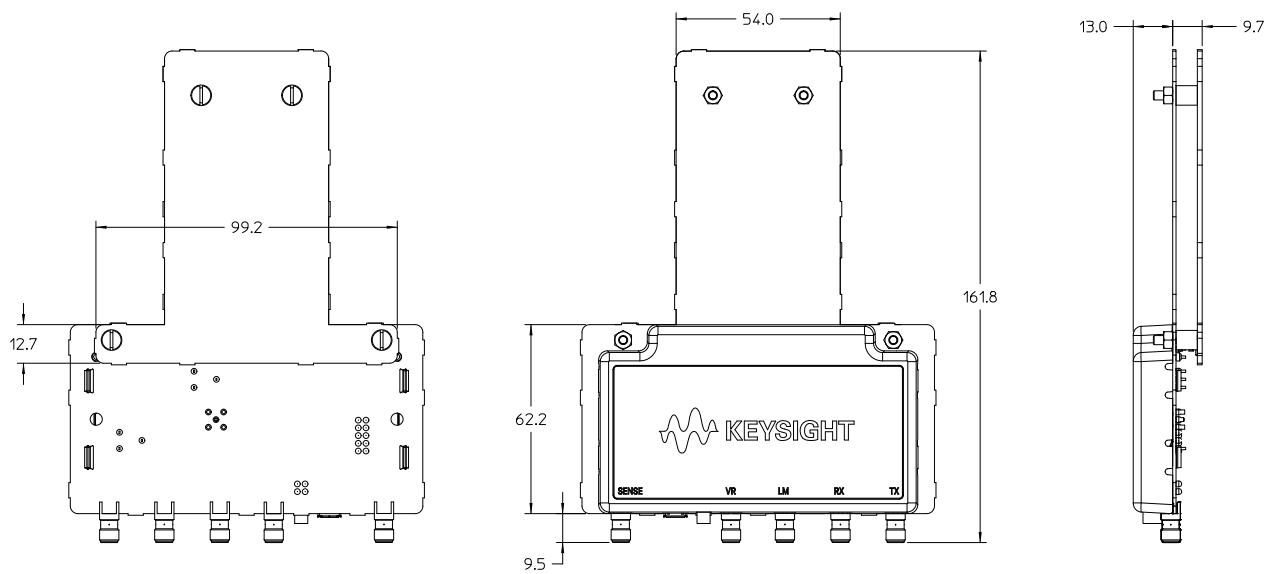

The N2134A 3-in-1 programmable NFC antenna provides 10 mm spacing between poller/listener coils.

N2135A 3-in-1 Programmable NFC Antenna Dimensions

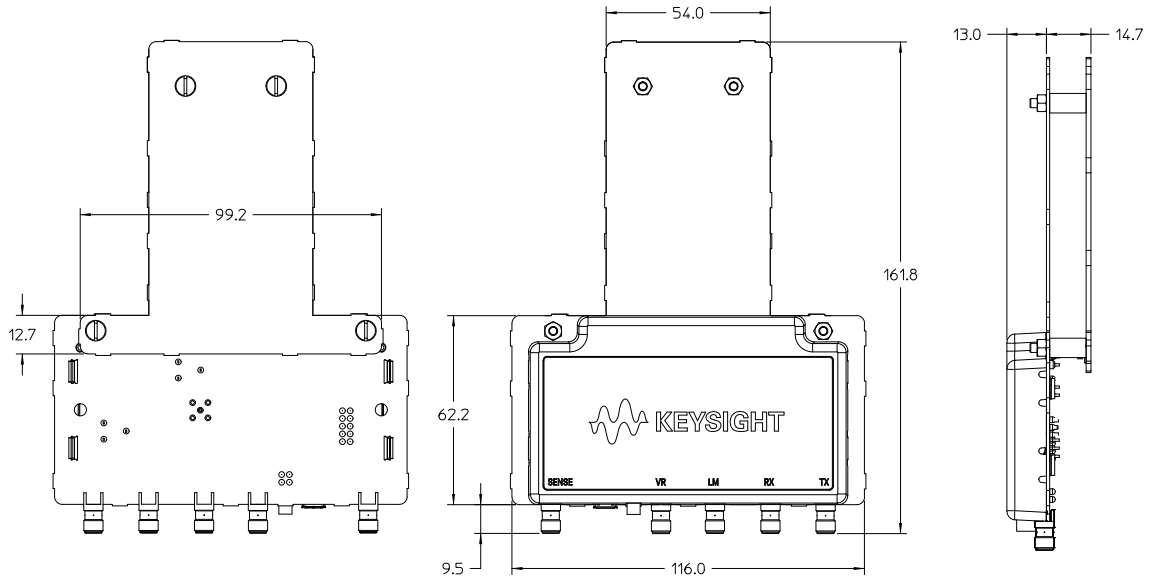

The N2135A 3-in-1 programmable NFC antenna provides 15 mm spacing between poller/listener coils.

TCI-II Programmable NFC Antenna



The TCI-II programmable NFC multi-coil antenna includes a Poller 3 and Listener 3 equivalent test antenna that can be quickly switched between various test modes for fast test throughput. The following shows a block diagram of Keysight's TCI-II programmable NFC antenna.

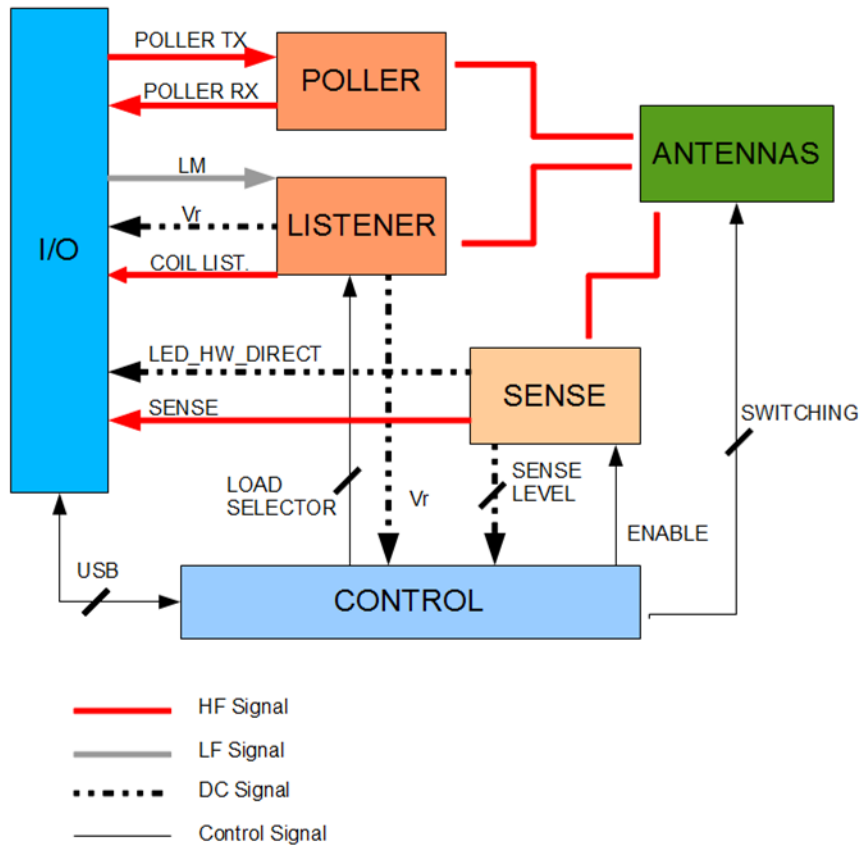

Installing the Required Software

The following software must be installed on the controller PC (in this order):

- 1 Keysight I/O Libraries version 17.2 or greater. See **"Installing the Keysight IO Libraries Suite"** on page 14.
- 2 .NET Framework 4.5.2 (included in NFC Test Application install package).
- 3 MATLAB Compiler Runtime 7.15 (included in NFC Test Application install package).
- 4 NFC Test Application software. See **"Installing the NFC Test Application software"** on page 14.

Installing the Keysight IO Libraries Suite

The controller PC must have installed Keysight I/O libraries version 17.2 or greater.

The Keysight IO Libraries Suite software can be downloaded from the Keysight web site at: www.keysight.com/find/iolib

Installing the NFC Test Application software

You must install the NFC Test Application on a controller PC that is connected to the InfiniiVision 3000T X-Series or 4000 X-Series oscilloscope via LAN or USB.

Download the NFC Test Application software from one of the following download web pages:

- <http://www.keysight.com/products/DSOXT3NFC> (for 3000T X-Series oscilloscopes)
- <http://www.keysight.com/products/DSOX4NFC> (for 4000 X-Series oscilloscopes)

To install the software:

- 1 Download the NFC Test Application install package from the Keysight web site to your controller PC.
- 2 Run the install package executable file and follow its instructions.

Installing the NFC Triggering License on the Oscilloscope

The NFC Test Application software requires the oscilloscope to have the NFC Triggering license:

- DSOXT3NFC on 3000T X-Series oscilloscopes.
- DSOX4NFC on 4000 X-Series oscilloscopes.

To install option licenses

On 3000T X-Series and 4000 X-Series oscilloscopes:

- 1** Follow the instructions on the Entitlement Certificate you received with your NFC option purchase.
- 2** Your license file will be delivered via e-mail.

License files are loaded from a USB storage device using the oscilloscope's File Explorer.

Adding Instruments Using Keysight Connection Expert

This procedure needs to be performed once for each oscilloscope and waveform generator used to perform NFC test measurements.

NOTE

The menus and dialog boxes shown here may differ slightly depending on the version of the Keysight IO Libraries Suite.

- 1 On the controller PC, click on the Keysight IO Control icon in the taskbar and choose **Connection Expert** from the popup menu.

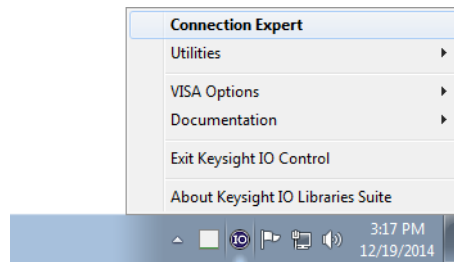

- 2 In the Keysight Connection Expert application, instruments connected to the controller's USB and GPIB interfaces as well as instruments on the same LAN subnet should automatically appear in the Instruments tab.

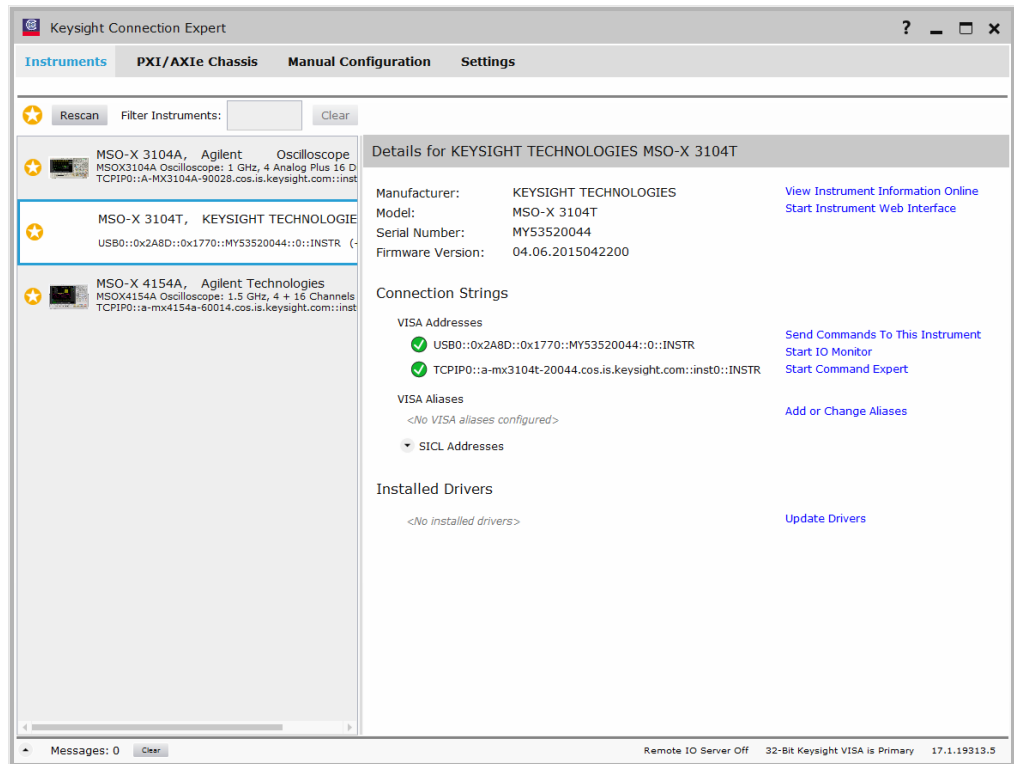

- 3 If your instrument does not appear, you can add it using the Manual Configuration tab.

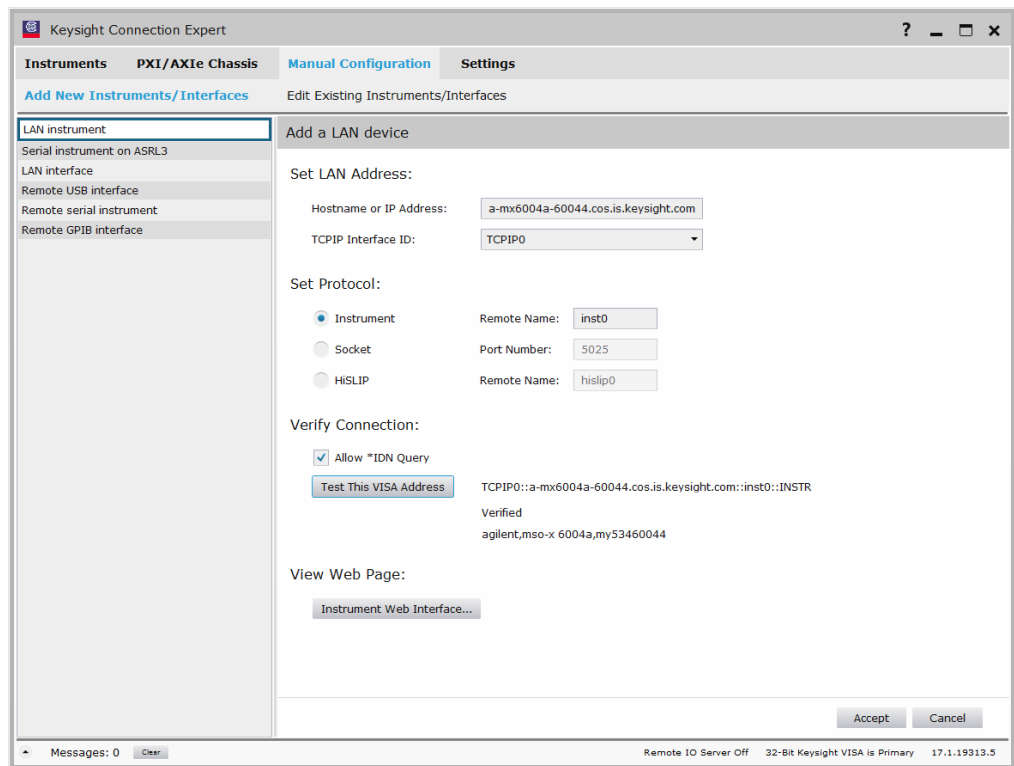

For example, to add a device:

- a Select **LAN instrument** in the list on the left.
- b Enter the oscilloscope's **Hostname** or **IP address**.
- c Select the protocol.
- d Select **Instrument** under Set Protocol.
- e Click **Test This VISA Address** to verify the connection.
- f If the connection test is successful, click **Accept** to add the instrument.

If the connection test is not successful, go back and verify the LAN connections and the oscilloscope setup.

- 4 Test some commands on the instrument:
- a In the Details for the selected instrument, click **Send Commands To This Instrument**.

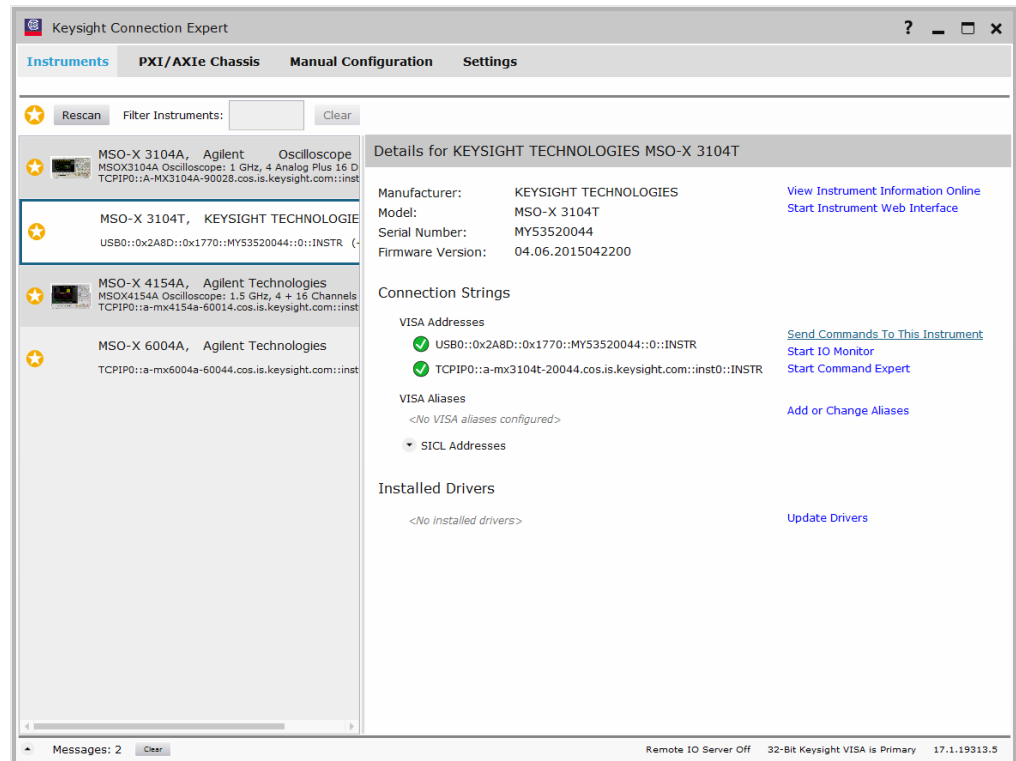

- b In the Keysight Interactive IO application, enter commands in the **Command** field and press **Send Command**, **Read Response**, or **Send & Read**.

1 Prerequisites

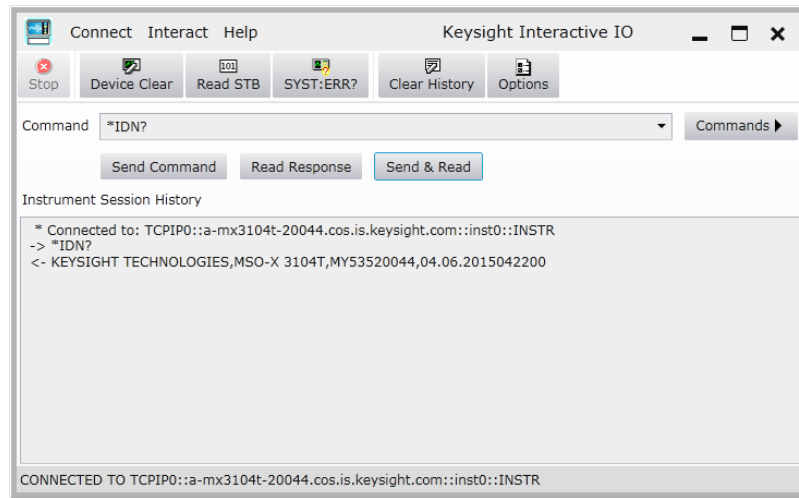

- c Choose **Connect > Exit** from the menu to exit the Keysight Interactive IO application.
- 5 In the Keysight Connection Expert application, choose **File > Exit** from the menu to exit the application.

2 Using the Test Application

Starting the NFC Test Application /	22
Creating or Opening a Test Project /	24
Setting Up the Test Environment /	25
Selecting Tests /	29
Configuring Tests /	31
Connecting the Test Equipment /	33
Running Tests /	38
Viewing Results /	53
Viewing/Exporting/Printing the Report /	59
Saving Test Projects /	64
Controlling the Application via a Remote PC /	65

Starting the NFC Test Application

- 1 Start the NFC test application:
 - On the controller PC's desktop, double-click the **NFC Test App** icon.

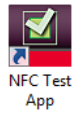

- Or, from the controller PC's Windows Start menu, choose **All Programs > Keysight InfiniiVision Applications > NFC Test App > NFC Test App**.

The NFC Test Application window appears.

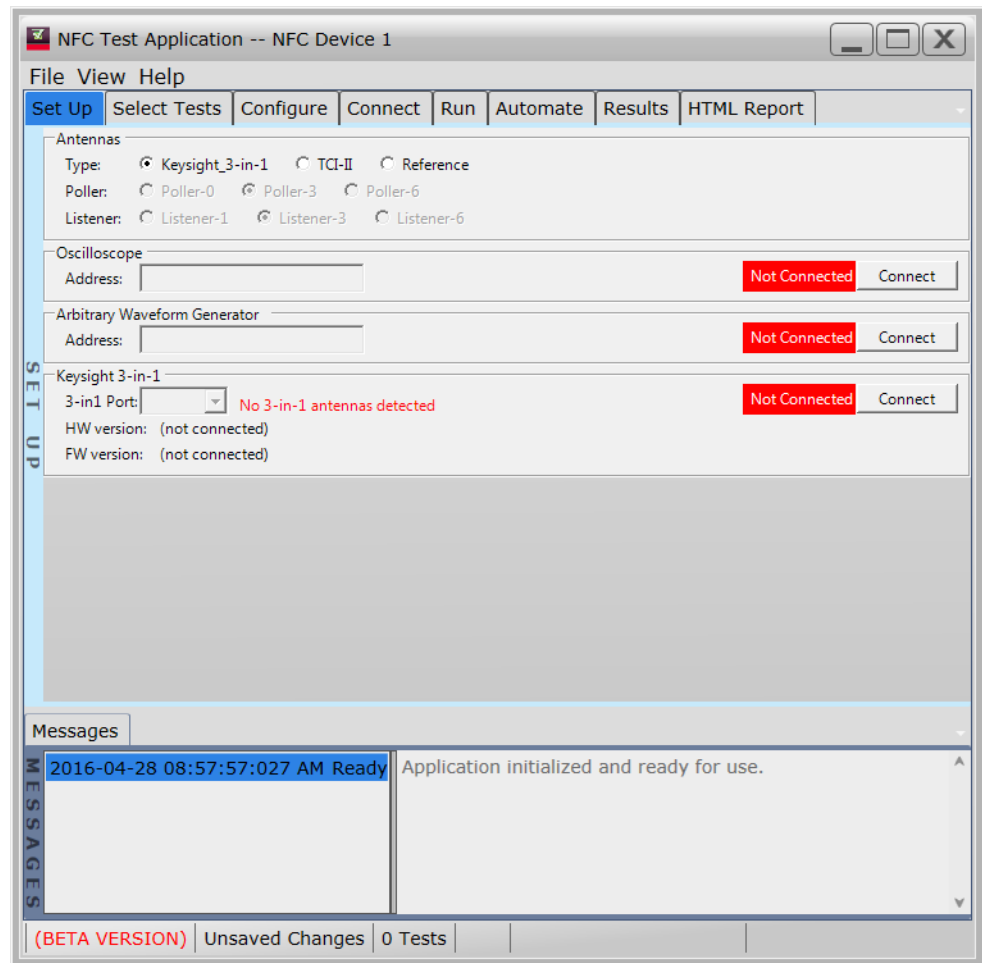

The default tab layout in the upper pane shows the steps you take when running the automated tests:

Set Up	Lets you identify the test environment, including information about the device and differential signal being tested.
Select Tests	Lets you select the tests you want to run. The tests are organized hierarchically so you can select all tests in a group. After tests are run, status indicators show which tests have passed, failed, or not been run, and there are indicators for the test groups.
Configure	Lets you configure test parameters (like oscilloscope channel).
Connect	Shows you how to connect the oscilloscope to the device under test for the tests that are to be run.
Run	Starts the automated tests.
Automate	Lets you construct command scripts that drive execution of the application.
Results	Contains more detailed information about the tests that have been run. You can change the thresholds at which marginal or critical warnings appear.
Html Report	Shows a test report that can be printed.

NOTE

You can drag tabs in the application wherever you like. To reset to the default tab layout, choose **View > Reset > Tab Layout**.

Next · ["Creating or Opening a Test Project"](#) on page 24

Creating or Opening a Test Project

To create a new test project:

- 1 Choose **File > New Project...** from the menu.

A new, empty project, with all the default settings is created.

To open an existing test project:

- 1 Choose **File > Open Project... > Browse...** from the menu.
- 2 In the Open dialog box, browse to a test project directory and select the desired ".proj" file.
- 3 Click **Open**.

See Also · ["To set load preferences"](#) on page 24

Next · ["Setting Up the Test Environment"](#) on page 25

To set load preferences

- 1 From the NFC test application's menu, choose **View > Preferences...**
- 2 In the Preferences dialog box, select the **Save/Load** tab.

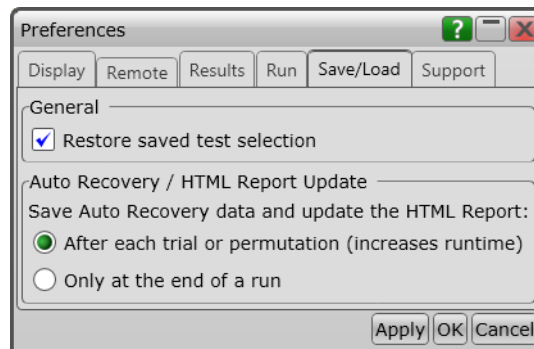

- 3 In the Save/Load tab, you can choose to restore saved test selections when loading a project.
- 4 Click **Apply** to save the changes and click **OK** to close the Preferences dialog box.

Setting Up the Test Environment

- 1 Click the **Set Up** tab.

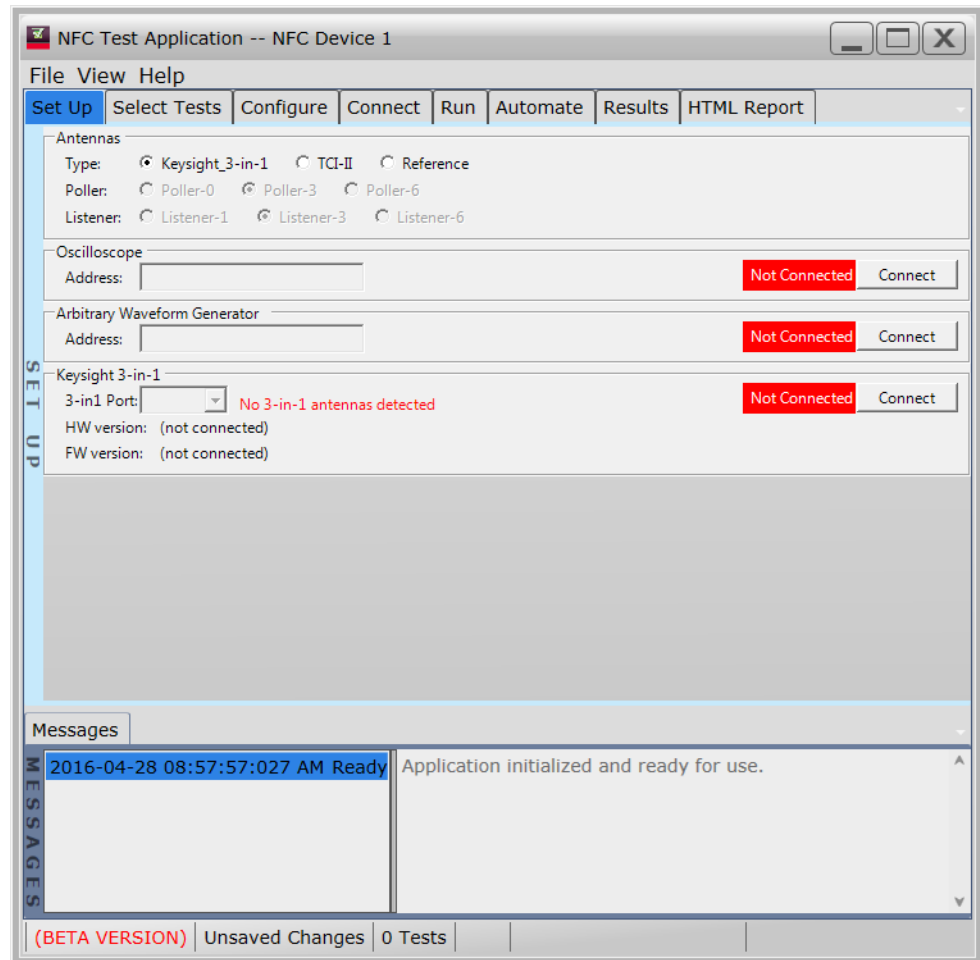

- 2 Select the **Antenna** type:
 - **Keysight_3-in-1** – This is the 3-in-1 antenna provided by Keysight. It integrates poller, listener, and resonant frequency test coil antennas into one printed-circuit board. The size of the coil is equivalent to Poller-3 and Listener-3 coil size.
 - **TCI-II** – This is the 2-in-1 antenna provided by Keysight. It integrates both poller and listener antennas into one printed-circuit board. The size of the coil is equivalent to Poller-3 and Listener-3 coil size.
 - **Reference** – These are the reference antennas specified by the NFC Forum. There are a total of 6 reference antennas available: Poller-0, Poller-3, Poller-6, Listener-1, Listener-3, Listener-6. The coil of the antenna get smaller with increasing number.

- 3 Enter the **Oscilloscope** address:
 - a Click **Connect**.
 - b In the "Connect to scope" dialog box, you can enter the oscilloscope's VISA address, VISA alias, or SICL address:

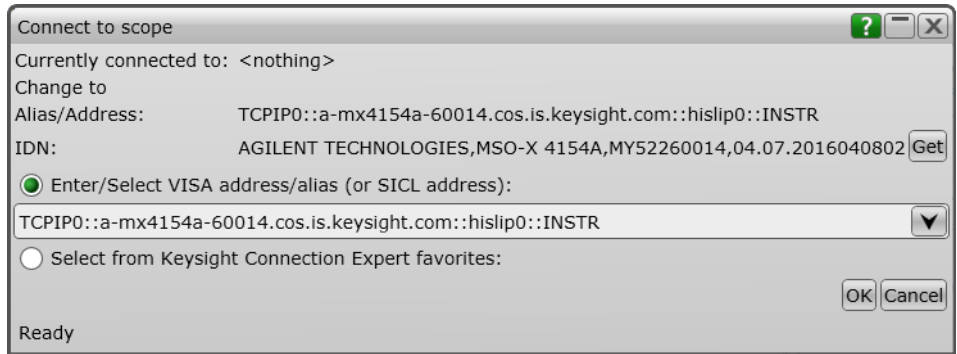

Or, you can select from Keysight Connection Expert favorites:

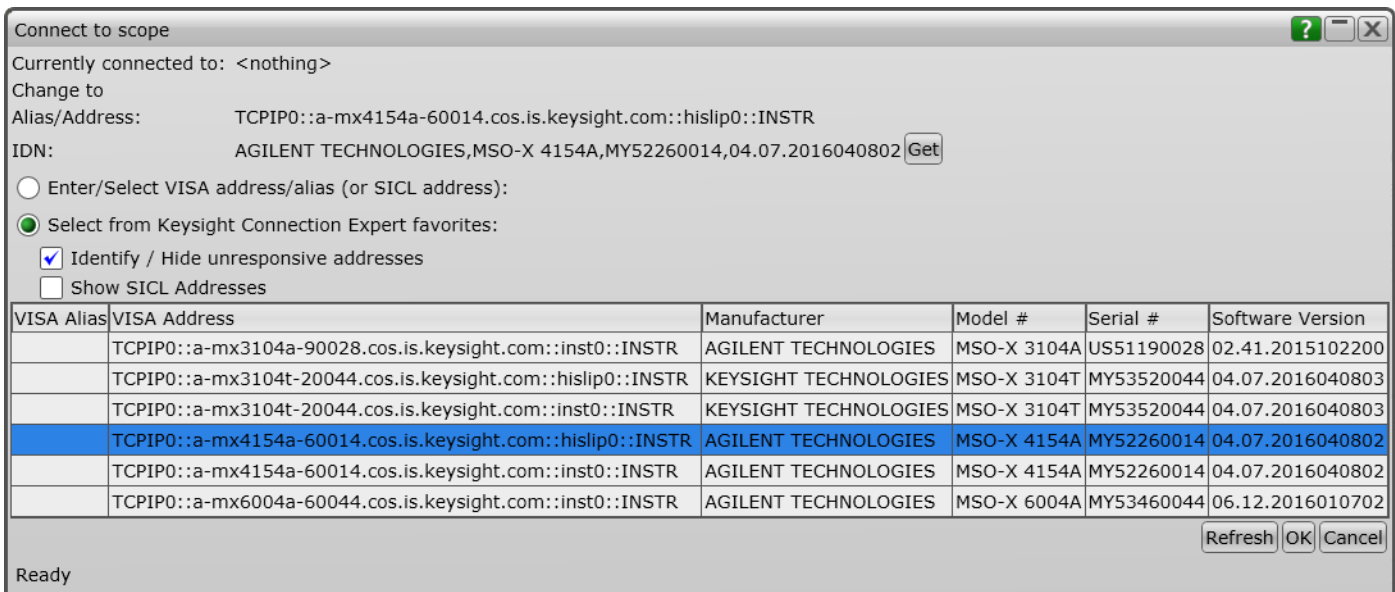

- c Click **Get** to view the instrument's identification string.
- 4 Enter the **Arbitrary Waveform Generator** address:
 - a Click **Connect**.
 - b In the "Connect to 33500" dialog box, you can enter the waveform generator's VISA address, VISA alias, or SICL address, or you can select from Keysight Connection Expert favorites.
 - c Click **Get** to view the instrument's identification string.

NOTE

Because the connection process also loads arbitrary waveforms into the waveform generator, it may take longer to connect to a waveform generator that has just been power-cycled.

- 5 If the Keysight 3-in-1 antenna type was selected, select the **3-in-1 Port**; then, click **Connect**.

If there are multiple 3-in-1 ports to choose from, and you are not sure which is correct, look at the USB devices shown in the Devices and Printers window in the Windows 7 operating system.

When the 3-in-1 antenna is connected, you will also see its HW and FW version information.

- 6 If the TCI-II antenna type was selected, select the **TCI Port**; then, click **Connect**.

If there are multiple TCI ports to choose from, and you are not sure which is correct, look at the USB devices shown in the Devices and Printers window in the Windows 7 operating system.

When the TCI-II antenna is connected, you will also see its HW and FW version information.

When the test environment is set up, the user interface looks something like:

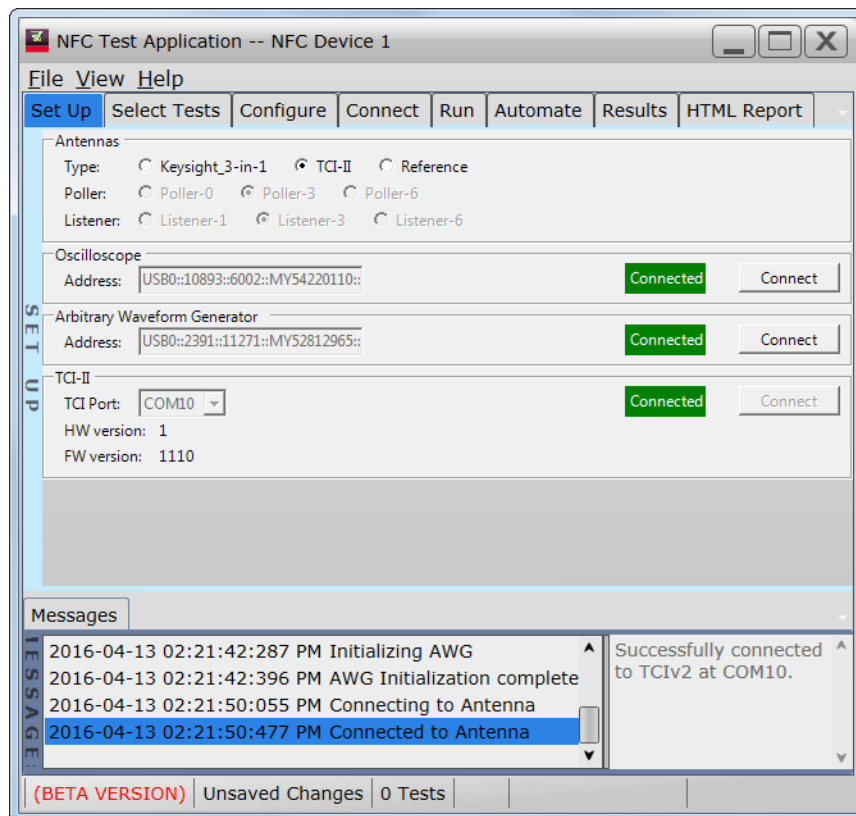

2 Using the Test Application

Next · ["Selecting Tests"](#) on page 29

Selecting Tests

- 1 Click the **Select Tests** tab.
- 2 Check the tests you want to run.

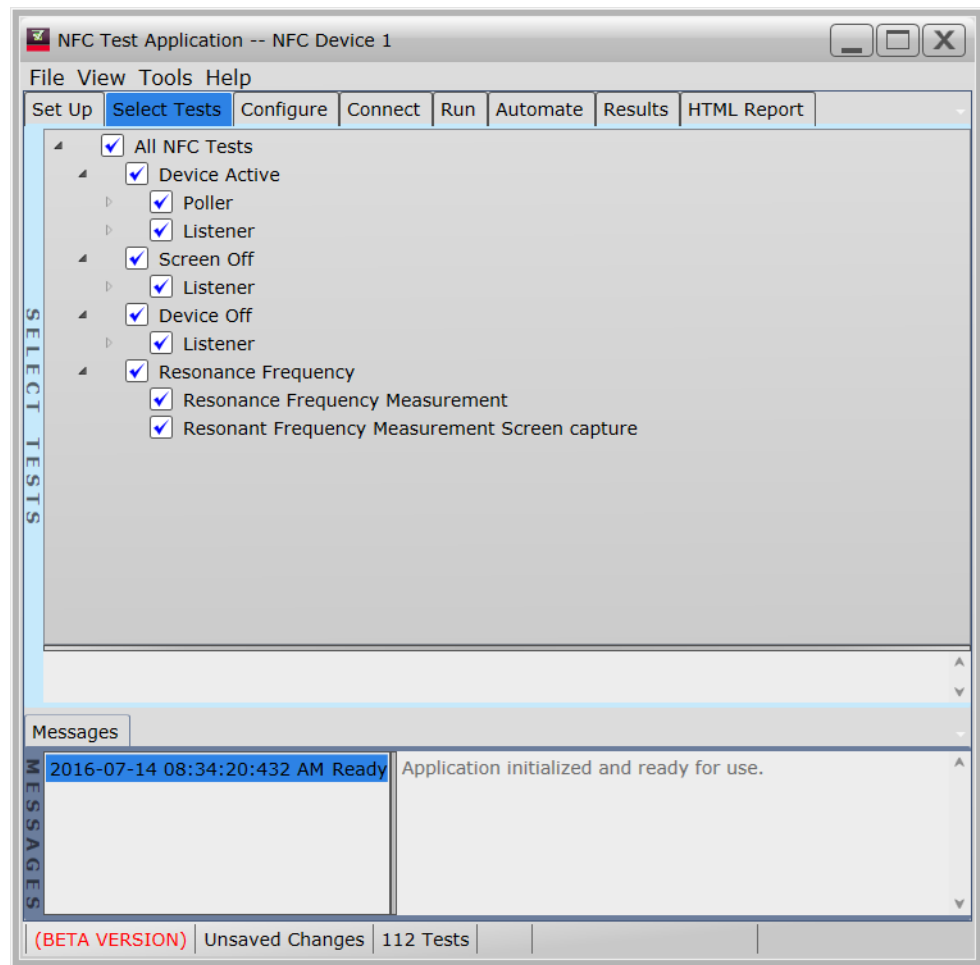

Some things to note:

- Checking a parent node/group will check all available sub-groups/tests.
- Unchecking a parent node/group will uncheck all sub-groups/tests.
- A parent node is checked if all subgroups are checked.
- A parent node is partially checked (square block) if ANY subgroup is unchecked.

When Tests Have Already Been Run

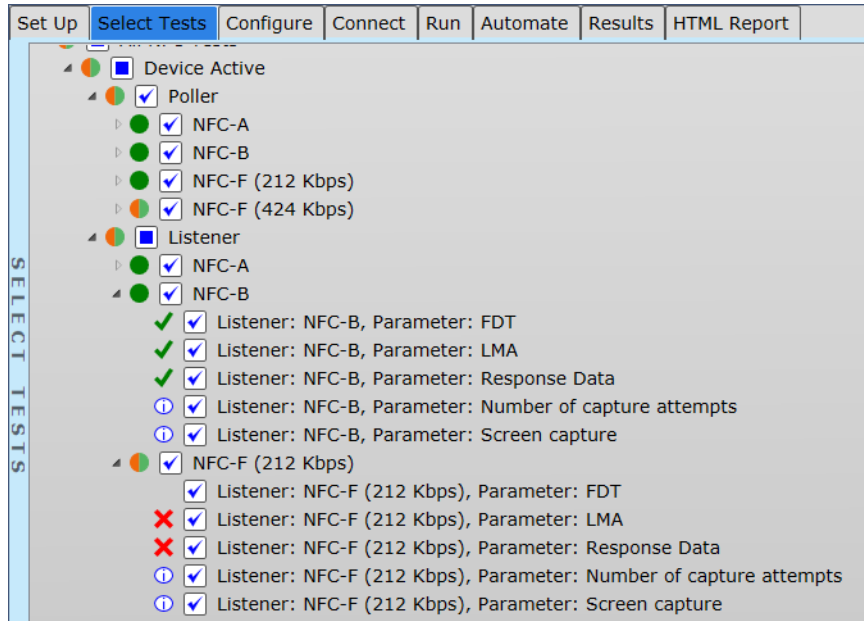

The marks have the following meanings:

	The test passed.
	The test failed.
	The test has not been run, or no tests in the group have been run.
	The test is currently running.
	Some tests in the group have run and passed.
	Some tests in the group have run and failed.
	Some tests in the group have passed and some have failed; not all of the tests have been run.
	Some tests in the group have passed and some have failed; all of the tests have run.
	All tests in the group have run and passed.
	All tests in the group have run and failed.

See Also • [Chapter 3](#), “About the Tests,” starting on page 69 (for more information on specific tests)

Next • ["Configuring Tests"](#) on page 31

Configuring Tests

- 1 Click the **Configure** tab.
- 2 Select the item you want to configure on the left side of the application window; then, select or enter your settings in the right side of the window.

A description of the selected configuration item also appears in the right side of the application window.

Note that you can also enter values in some of the drop-down selection fields. Entered values are checked for validity.

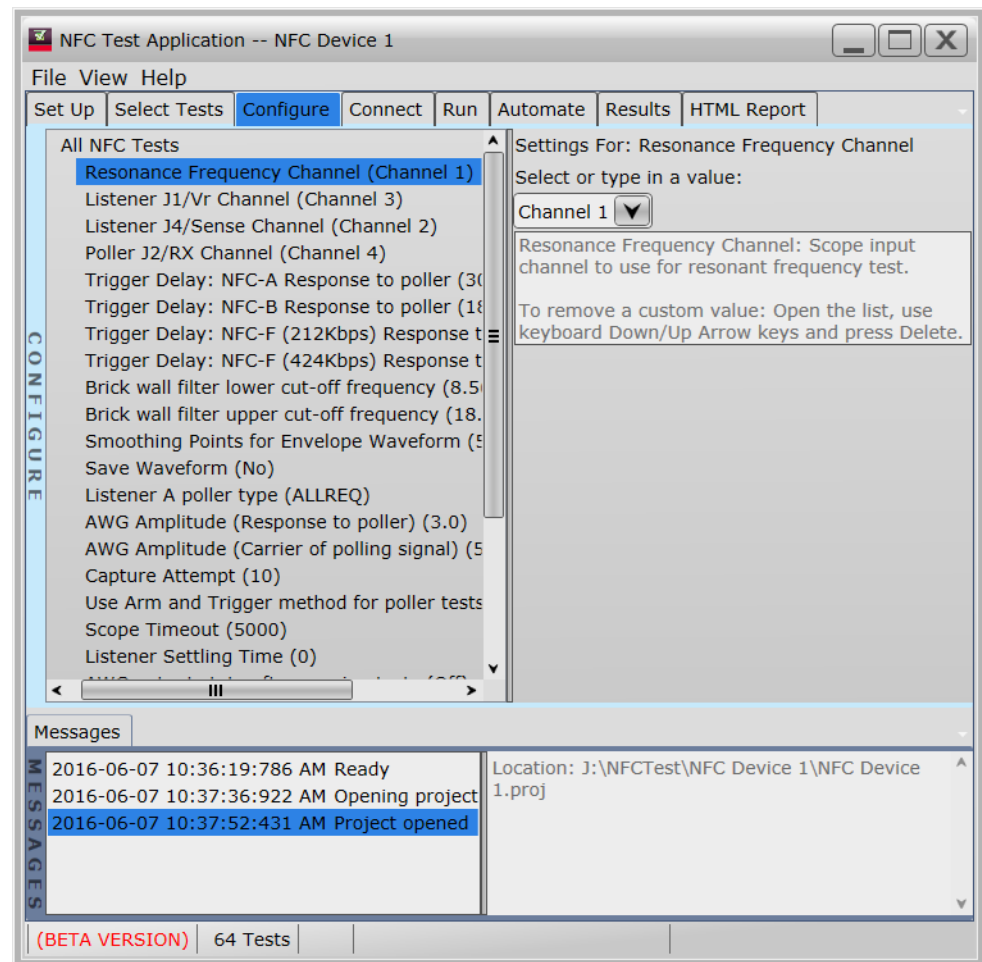

TIP

A quick way to reset all configuration options and delete all test results is to create a new project (see [page 24](#)). The new project will have default configuration options.

To see the automation variable name for a selected configuration item, enable remote interface hints (see ["To enable remote interface hints"](#) on page 67). After doing that, the right side description will show the automation variable name. For example:

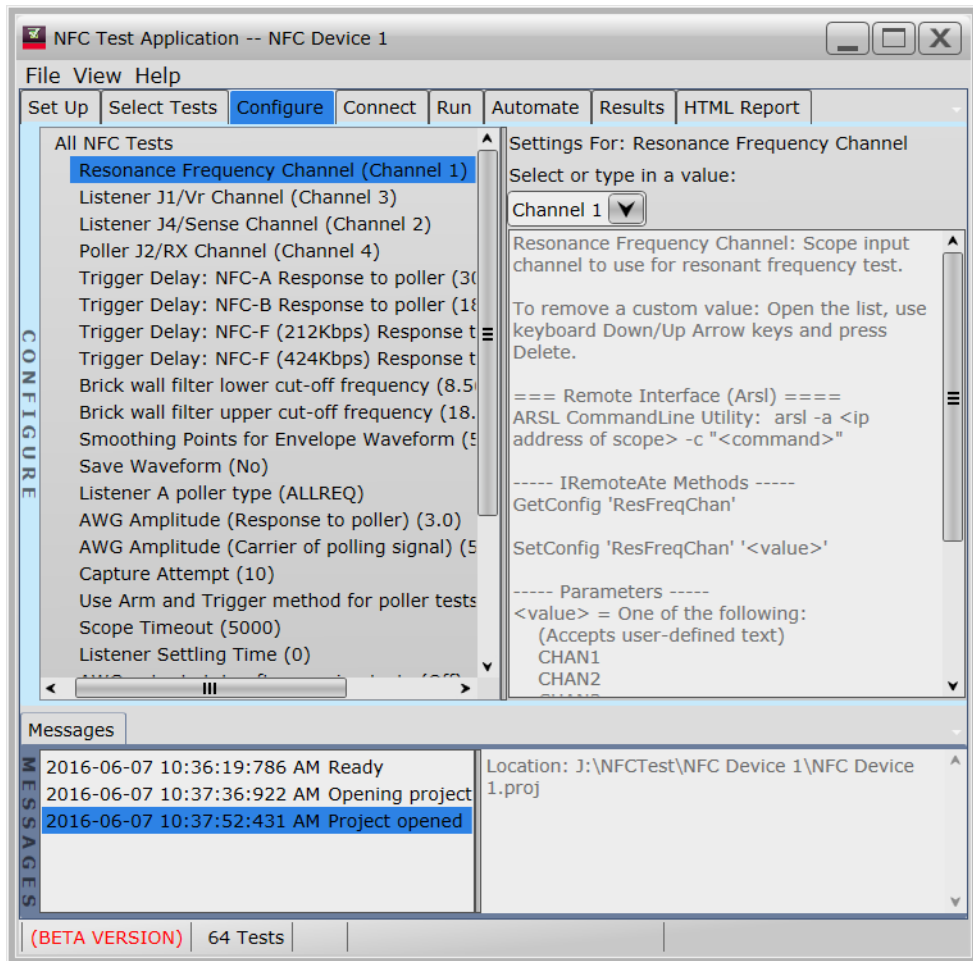

Next · ["Connecting the Test Equipment"](#) on page 33

Connecting the Test Equipment

- 1 Click the **Connect** tab.
- 2 Follow the displayed instructions for connecting the test equipment.

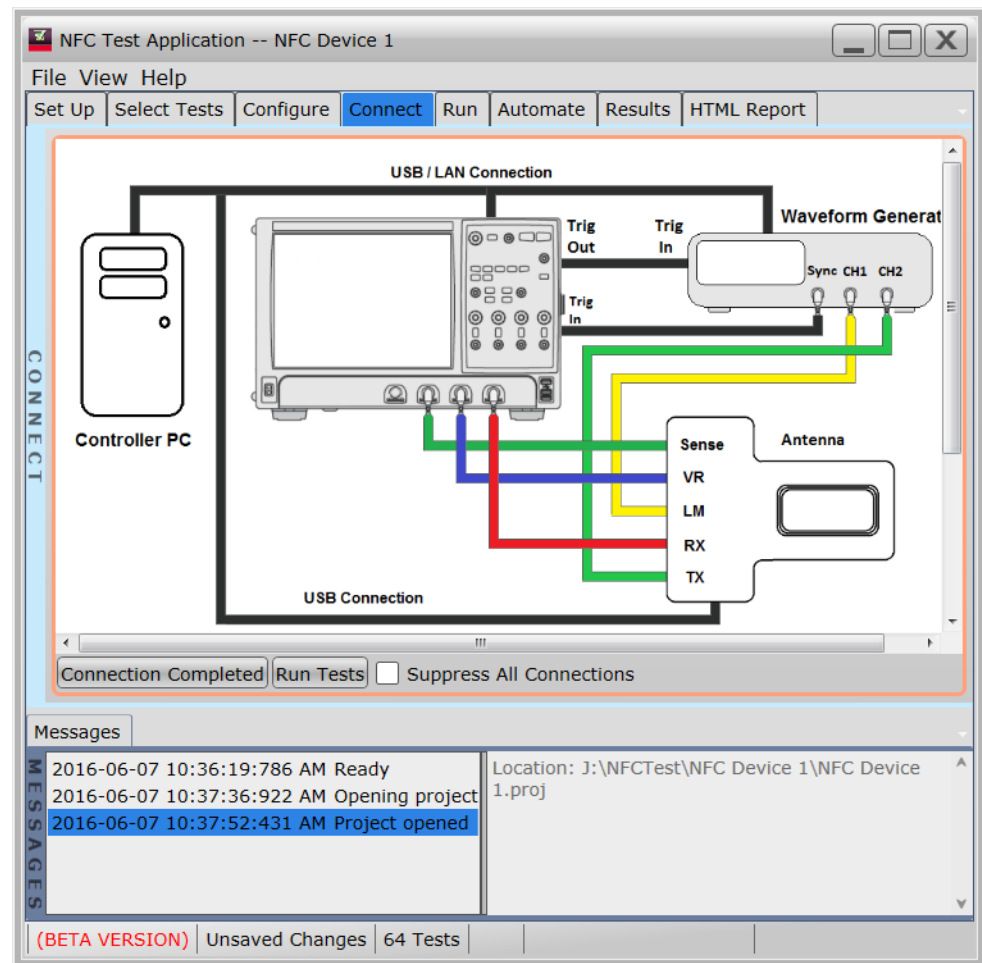

- 3 Place the device under test on the NFC antenna.
- 4 When the test equipment connections have been made, click the **Connection Completed** button.

For more information on test equipment connections, see:

- ["Connections for a Keysight 3-in-1 Antenna"](#) on page 34
- ["Connections for a TCI-II Antenna"](#) on page 35
- ["Connections for a Reference Poller Antenna"](#) on page 36
- ["Connections for a Reference Listener Antenna"](#) on page 37

Next • ["Running Tests"](#) on page 38

Connections for a Keysight 3-in-1 Antenna

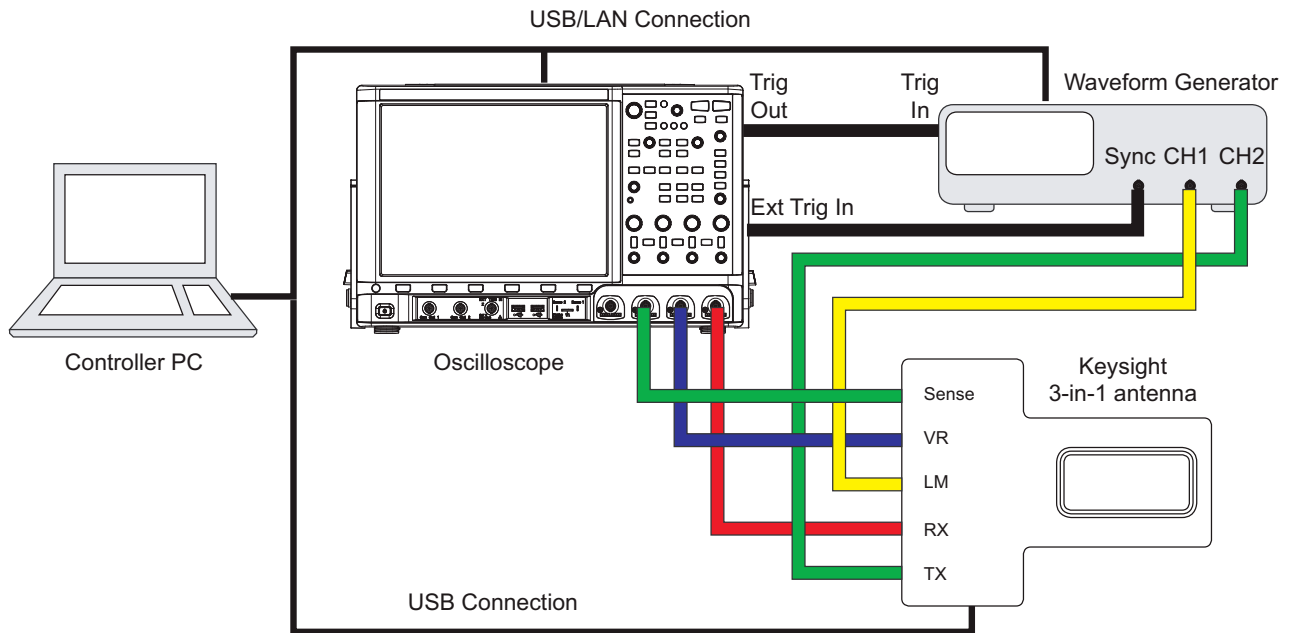

- 1 The oscilloscope is connected to the controller PC using a LAN or USB connection.
- 2 The waveform generator is connected to the PC using a LAN or USB connection.
- 3 The Keysight 3-in-1 antenna is connected to the PC using a USB connection.
- 4 The Trigger Out (Label: Trig Out) port, which is located on the rear of the oscilloscope is connected to the Trigger In (Label: Ext Trig) of the waveform generator.
- 5 Connect Sense port of the Keysight 3-in-1 antenna to Channel 2 of the oscilloscope.
- 6 Connect VR port of the Keysight 3-in-1 antenna to Channel 3 of the oscilloscope.
- 7 Connect RX port of the Keysight 3-in-1 antenna to Channel 4 of the oscilloscope.
- 8 Connect LM port of the Keysight 3-in-1 antenna to Channel 1 of the waveform generator.
- 9 Connect TX port of the Keysight 3-in-1 antenna to Channel 2 of the waveform generator.

*The connections to the oscilloscope (Sense, VR, and RX) can be changed in the Configure tab.

Connections for a TCI-II Antenna

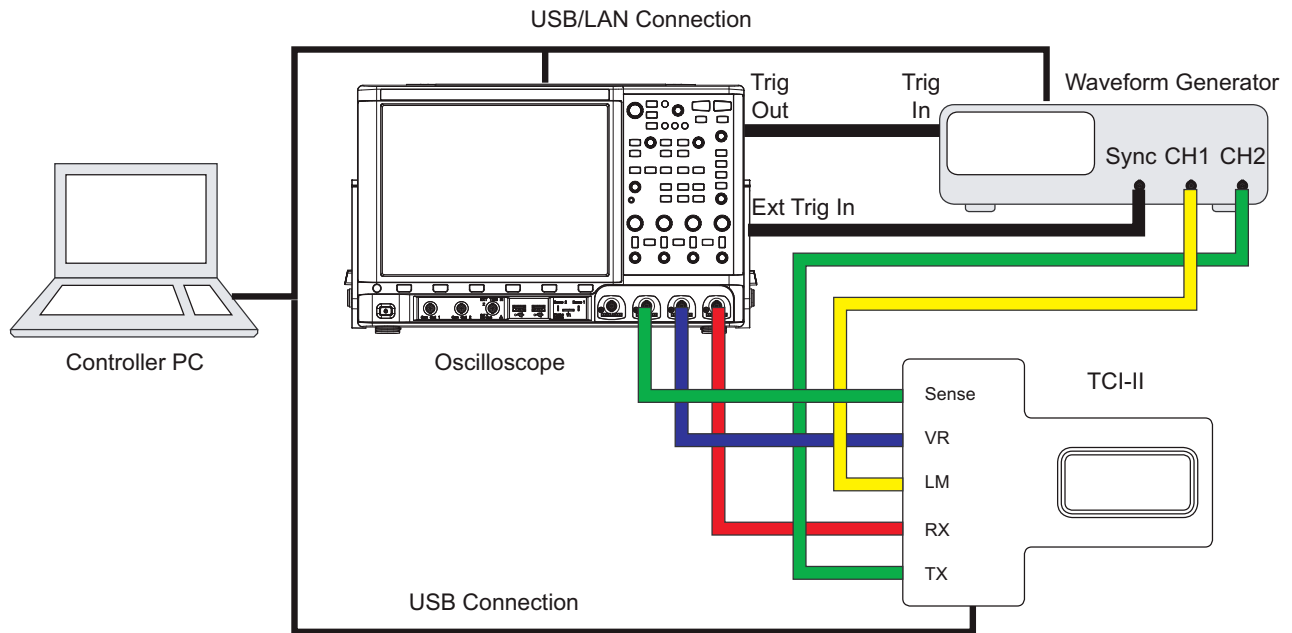

- 1 The oscilloscope is connected to the controller PC using a LAN or USB connection.
- 2 The waveform generator is connected to the PC using a LAN or USB connection.
- 3 The TCI-II is connected to the PC using a USB connection.
- 4 The Trigger Out (Label: Trig Out) port, which is located on the rear of the oscilloscope is connected to the Trigger In (Label: Ext Trig) of the waveform generator.
- 5 Connect Sense port of the TCI-II to Channel 2 of the oscilloscope.
- 6 Connect VR port of the TCI-II to Channel 3 of the oscilloscope.
- 7 Connect RX port of the TCI-II to Channel 4 of the oscilloscope.
- 8 Connect LM port of the TCI-II to Channel 1 of the waveform generator.
- 9 Connect TX port of the TCI-II to Channel 2 of the waveform generator.

*The connections to the oscilloscope (Sense, VR, and RX) can be changed in the Configure tab.

Connections for a Reference Poller Antenna

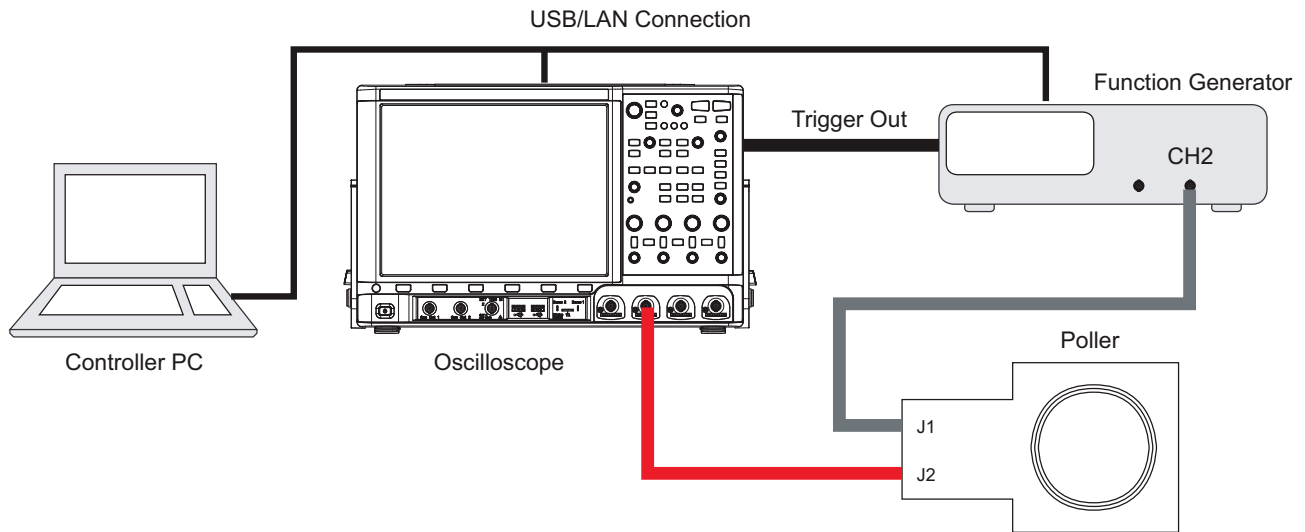

- 1 The oscilloscope is connected to the controller PC using a LAN or USB connection.
- 2 The waveform generator is connected to the PC using a LAN or USB connection.
- 3 Connect J2 port of the Reference Poller to Channel 4 of the oscilloscope.
- 4 Connect J1 port of the Reference Poller to Channel 2 of the waveform generator.

* The connections to the oscilloscope (Sense, VR, and RX) can be changed in the Configure tab.

Connections for a Reference Listener Antenna

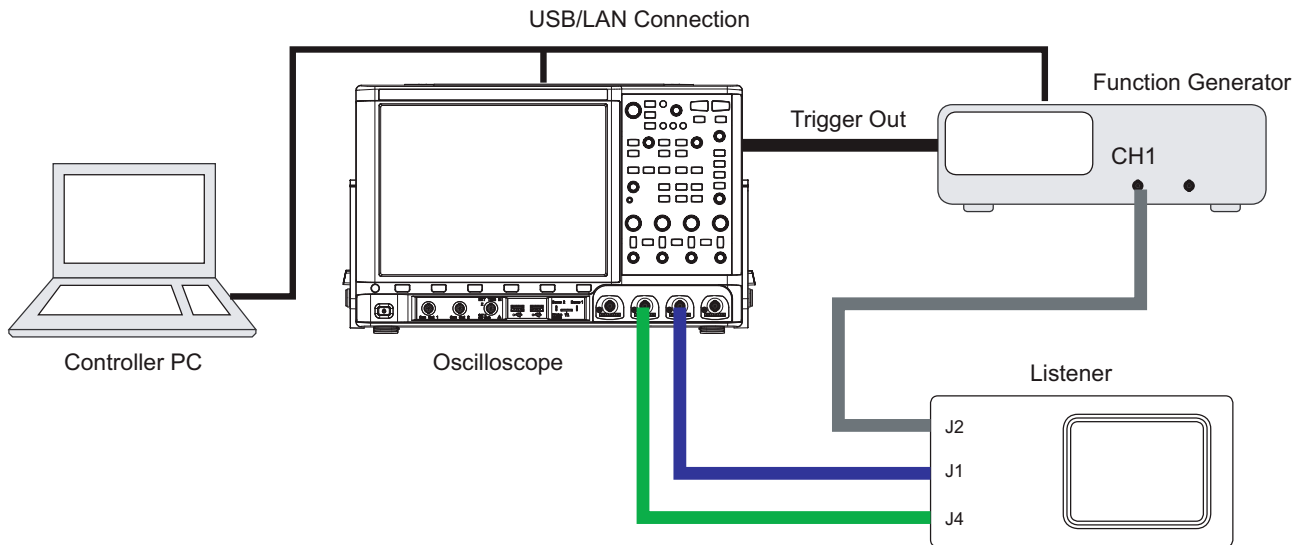

- 1 The oscilloscope is connected to the controller PC using a LAN or USB connection.
 - 2 The waveform generator is connected to the PC using a LAN or USB connection.
 - 3 The Trigger Out (Label: Trig Out) port, which is located on the rear of the oscilloscope is connected to the Trigger In (Label: Ext Trig) of the waveform generator.
 - 4 Connect J4 port of the Reference Listener to Channel 2 of the oscilloscope.
 - 5 Connect J1 port of the Reference Listener to Channel 3 of the oscilloscope.
 - 6 Connect J2 port of the Reference Listener to Channel 1 of the waveform generator.
- * The connections to the oscilloscope (Sense, VR, and RX) can be changed in the Configure tab.

Running Tests

NOTE

You should allow the oscilloscope to warm-up at least 30 minutes before running any measurement tests.

TIP

It is a good idea to calibrate the oscilloscope at least once a year or when the Calibration Δ Temp is greater than ± 5 °C. The Calibration Δ Temp is found using the oscilloscope's front panel, by pressing the **[Utility]** key followed by the **Service** and **User Cal Status** softkeys.

The Run tab's settings let you run the selected tests once or multiple times. When you run tests multiple times, there are options for selecting which trials are stored and how long tests are run.

To run the selected tests once:

- 1 Select the Run tab, make sure the **Once** "run until" option is selected, and click the big **Run** button.

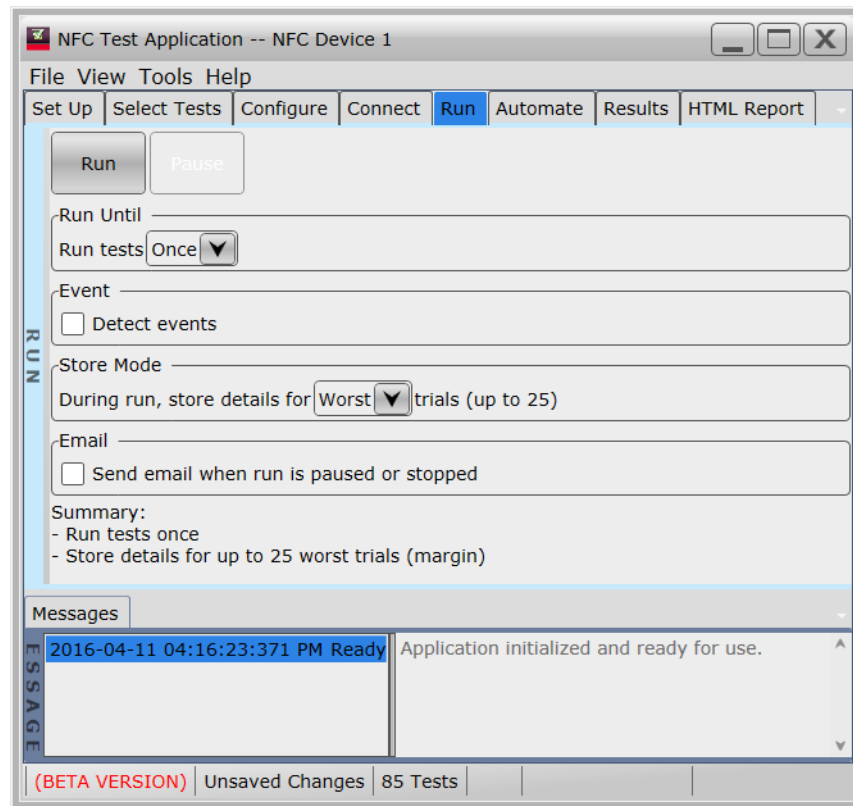

For more information on additional run options, see:

- **"To select the "store mode""** on page 40

- "To run multiple times" on page 41
 - "To send email on pauses or stops" on page 43
 - "To pause or stop on events" on page 43
 - "To specify the event" on page 45
- 2 If there are existing test results, you are asked if you would like to keep them (and append new results) or delete them.

If you would like to keep the existing test results to compare against new results, click **Append**.

Click **Replace** if you would like to delete the existing results for the currently selected tests.

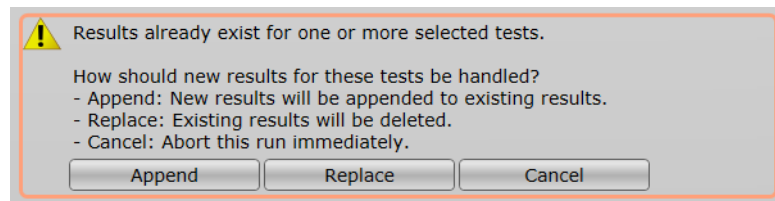

- 3 While the tests are running, status information appears (next to the **Stop** and **Pause** buttons) to inform you about the test progress.



- 4 When the tests are complete, there is a "Run ended" message, the overall run status is displayed, and the **Stop** button changes back to **Run**.

2 Using the Test Application

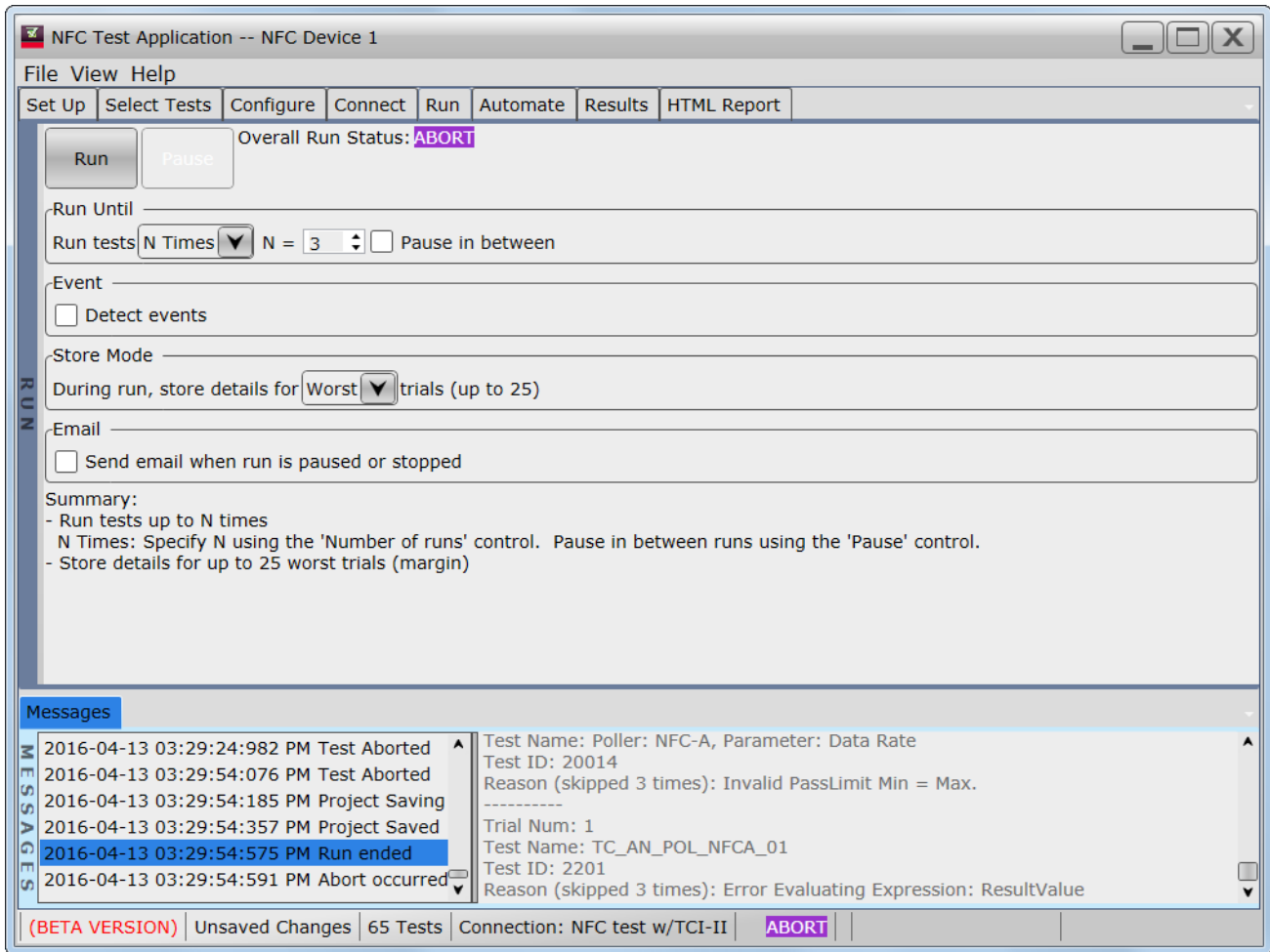

- See Also
- ["To set the display preferences"](#) on page 45
 - ["To set the run preferences"](#) on page 47
- Next
- ["Viewing Results"](#) on page 53

To select the "store mode"

When running tests multiple times, you can select which trials are stored.

- 1 Select the Run tab.
- 2 In the Store Mode area, select:

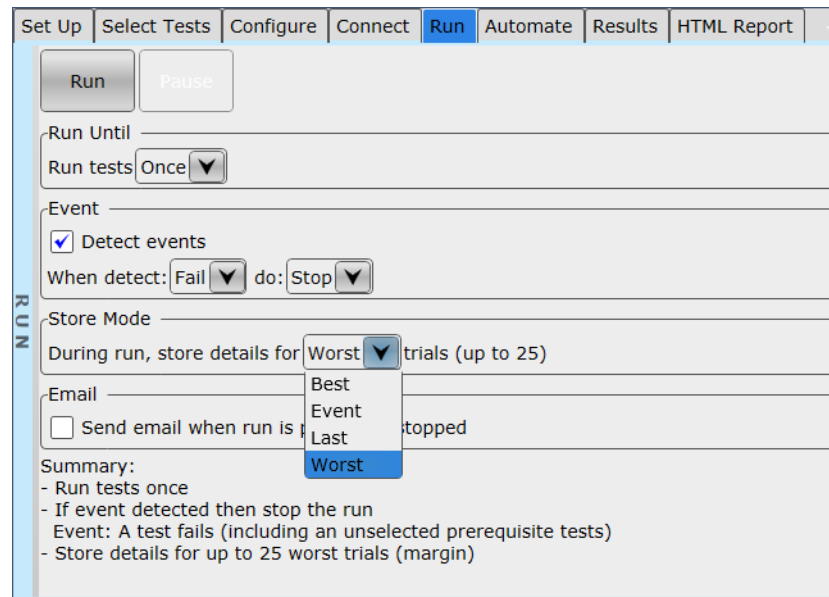

- **Best** – stores the results of the best N trials.
- **Event** – stores the results of N trials in which the event is detected. The event is determined in the Event area. See ["To specify the event"](#) on page 45.
- **Last** – stores the results of the last N trials.
- **Worst** – stores the results of the worst N trials.

Up to 25 trials can be stored.

If you change the Store Mode when test results exist, the existing results will be deleted.

The Store Mode selection affects the trial display options in the Report tab of the Preference dialog box. See ["To set trial display preferences"](#) on page 55.

To run multiple times

The "run until" option lets you specify whether tests are run once or multiple times.

- 1 Select the Run tab.
- 2 In the Run Until area, select:

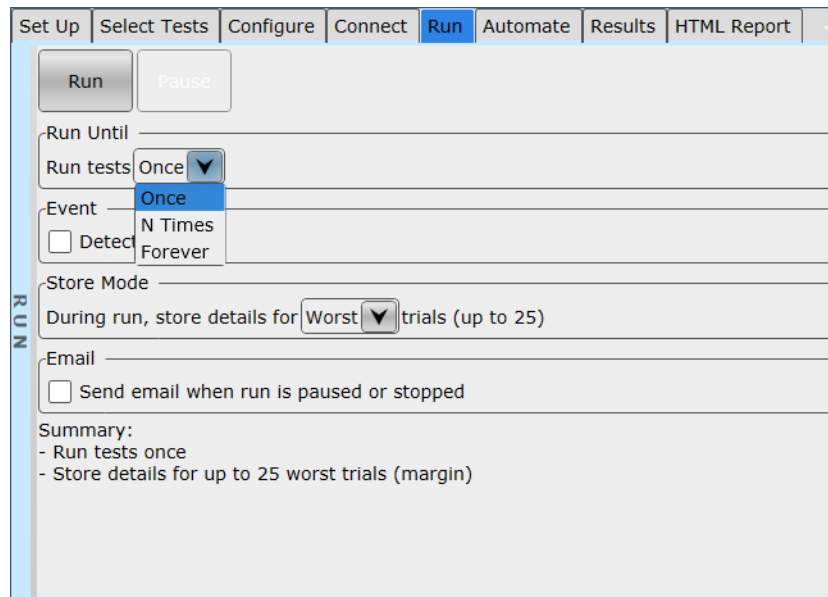

- **Forever** – runs the tests repeatedly until you click the **Cancel** button.
- **N Times** – runs the tests N times. When this option is selected, you can specify the number of runs and whether pauses occur between each run.

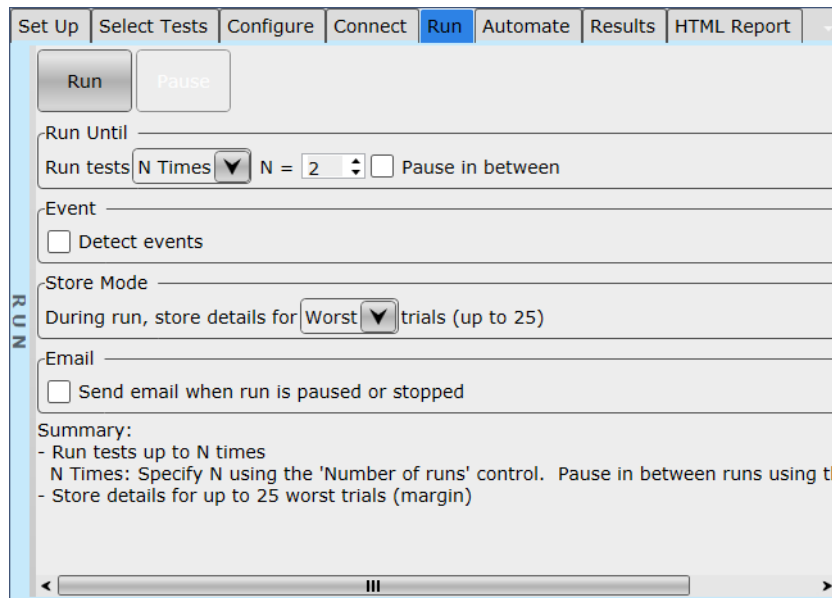

- **Once** – runs the tests only once. This is the default setting.

When multiple runs are selected, you can use the trial display options in the Report tab of the Preference dialog box to specify how many trials are displayed in the test report. See **"To set trial display preferences"** on page 55.

To send email on pauses or stops

You can configure the test application to send email whenever a run pauses or ends.

- 1 Select the Run tab.
- 2 In the Email area, check **Send email when run is paused or stopped**.
- 3 Enter your **To** and **From** email addresses and the hostname of the **SMTP Server**.

The screenshot shows the 'Run' configuration tab. The 'Email' section is expanded, and the 'Send email when run is paused or stopped' checkbox is checked. The 'To' and 'From' fields are filled with 'me@MyCompany.com', and the 'SMTP Server' field is filled with 'mailserver.MyCompany.com'. A summary box at the bottom lists the current configuration: 'Run tests once', 'Store details for up to 25 worst trials (margin)', and 'Send email when run pauses or stops'.

Pauses can occur between runs when running a specific number of times (see "**To run multiple times**" on page 41) or when pausing on an event (see "**To pause or stop on events**" on page 43).

To pause or stop on events

You can set up test runs to pause or stop on events which are checked at the end of each test..

- 1 Select the Run tab.
- 2 In the Event area, check **Detect events**.
- 3 In the **do:** drop-down selection field that appears, select either:

2 Using the Test Application

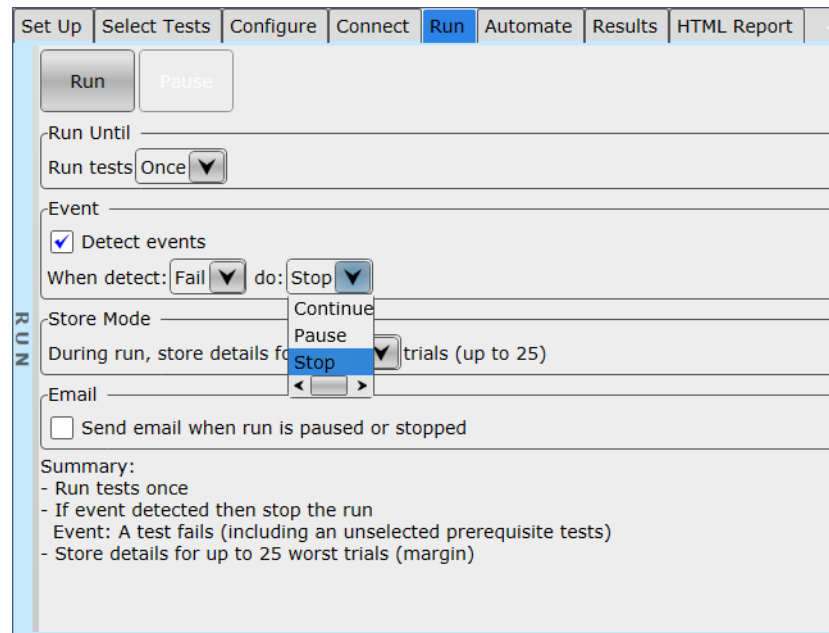

- **Continue** – causes the run to continue when the event is detected.
 - **Pause** – causes the run to pause when the event is detected.
 - **Stop** – cause the run to stop when the event is detected.
- 4 In the Event area, specify the type of event. See **"To specify the event"** on page 45.

Pauses or stops can be set up to automatically send email (see **"To send email on pauses or stops"** on page 43).

To specify the event

In the Store Mode area when you have selected Event (see **"To select the "store mode""** on page 40) or in the Run Until area when you have selected to pause or stop on an event (see **"To pause or stop on events"** on page 43), the Event area appears so that you can specify the event.

- 1 In the Event area, select the type of event:

The screenshot shows the 'Run' configuration dialog box with the 'Run' tab selected. The 'Event' section is expanded, showing the following settings:

- Detect events
- When detect: Fail (selected) do: Stop
- Store Mode: Margin (selected)
- During run, store details for Worst (selected) trials (up to 25)
- Send email when run is paused or stopped

The 'Summary' section displays the following configuration:

- Run tests once
- If event detected then stop the run
- Event: A test fails (including an unselected prerequisite tests)
- Store details for up to 25 worst trials (margin)

- **Fail** – causes the event to fire when a prerequisite test or selected test fails..
- **Margin < N** – causes the event to fire when a test generates a margin < specified. When this option is selected, enter the minimum required margin percentage.
- **Pass** – causes the event to fire when a test passes (excluding prerequisite tests).

A tilde "~" character in the event selection drop-down shows that the event is unavailable. If you select an event type that is not available, a dialog box tells you why.

To set the display preferences

Information, warning, and error conditions can occur while running tests. The display preferences let you choose whether message dialog boxes are shown. And, there are other display preferences that affect what happens as tests are run.

- 1 From the NFC test application's menu, choose **View > Preferences...**
- 2 In the Preferences dialog box, select the **Display** tab.

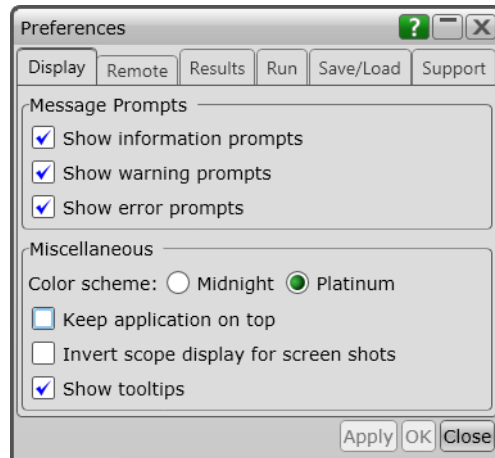

3 In the Display tab, you can choose to show the following types of message dialog boxes:

- Information dialog boxes.
- Warning dialog boxes.
- Error dialog boxes.

NOTE

Messages that require you to make a choice, such as "OK/Cancel" and "Yes/No" are always enabled.

4 Also, you can choose to:

- Change the **Color scheme** – You can choose between the darker **Midnight** color scheme or the lighter **Platinum** color scheme.
- **Invert scope display for screen shots** – (white background) when the application captures the screen shots.
- **Keep application on top** – Always keep the application's main dialog box on the top of other windows. Note that the mid-run dialog boxes are always displayed on the top.
- **Show tooltips** – By enabling this option, the tooltips appear as you move the pointer over various controls in the application.

5 Click **Apply** to save the changes and click **OK** to close the Preferences dialog box.

To set the run preferences

Information, warning, and error conditions can occur while running tests. The display preferences let you choose whether message dialog boxes are shown. And, there are other display preferences that affect what happens as tests are run.

- 1 From the NFC Test Application's menu, choose **View > Preferences...**
- 2 In the Preferences dialog box, select the **Run** tab.

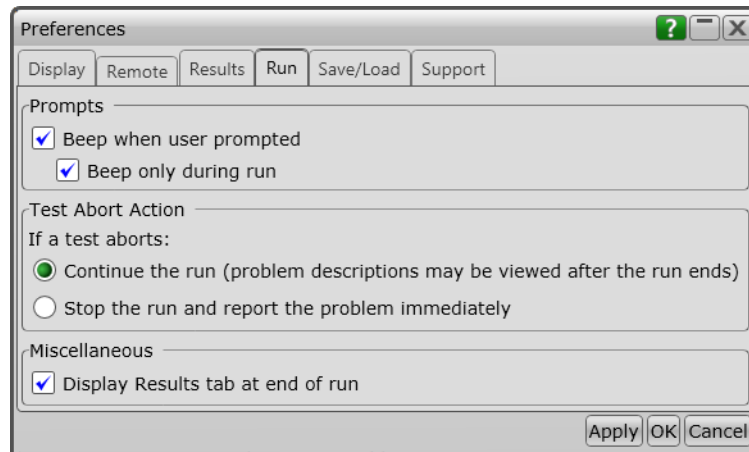

- 3 In the Run tab, choose if/when you would like beeps to occur during test runs:
 - **Beep when user prompted** – causes the controller PC to beep when there is a prompt for user input.
 - **Beep only during run** – specifies that beeps only occur during runs.
- 4 Select the **Test Abort Action**.
You can choose to continue the run or stop the run.
- 5 Select or clear the **Display Results tab at end of run** check box option.
- 6 Click **Apply** to save the changes and click **OK** to close the Preferences dialog box.

Automating the Application

The Automation tab lets you construct command scripts that drive execution of the application.

You can select from two modes, **Script** and **Files**:

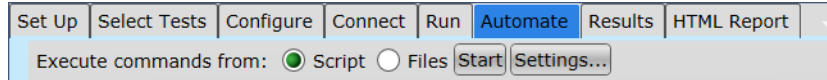

See:

- ["To enter commands in Script mode"](#) on page 48
- ["To enter commands in Files mode"](#) on page 50
- ["To begin Script or Files execution"](#) on page 51
- ["To display automation settings status"](#) on page 51
- ["To try a command line"](#) on page 51

To enter commands in Script mode

In Script mode, the application will execute the commands it finds in the script text box:

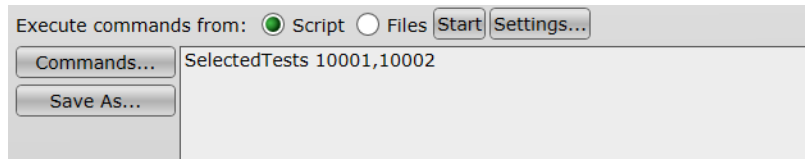

You may either type in commands (one per line) or use the **Commands...** generator to construct them. A script may be saved to a text file to make it easy to switch to the **Files** automation method.

The command generator is opened by clicking **Commands...**. It can generate single commands or sample scripts that demonstrate how commands work together.

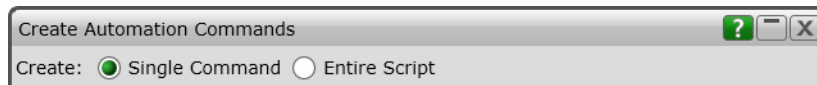

In **Single Command** mode, select the tab that corresponds to the real application tab containing the controls you want to affect. Then, select which action you want to perform. The screen will then show you what automation command performs that action. Most commands are shown with placeholder parameters along with instructions on how to customize them:

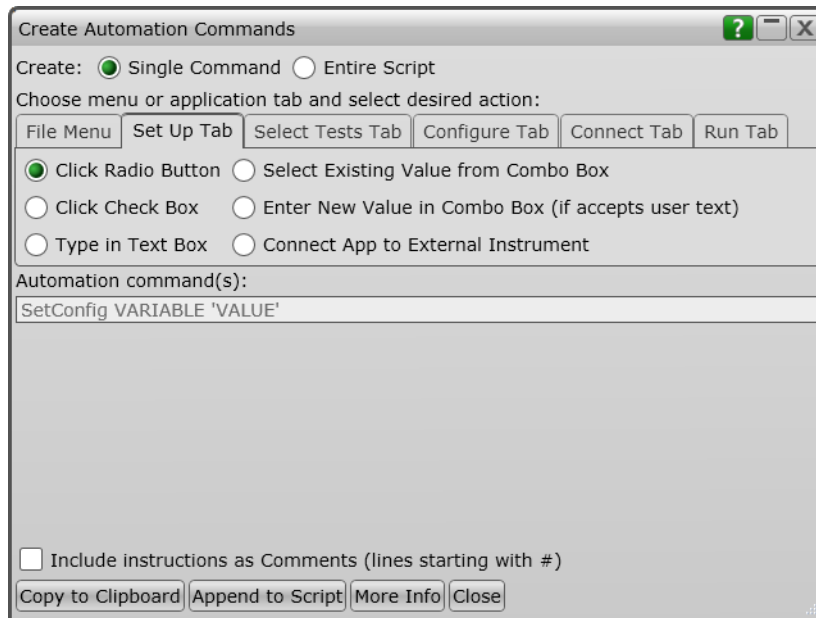

In **Entire Script** mode, select a script that describes a task you would like to know more about:

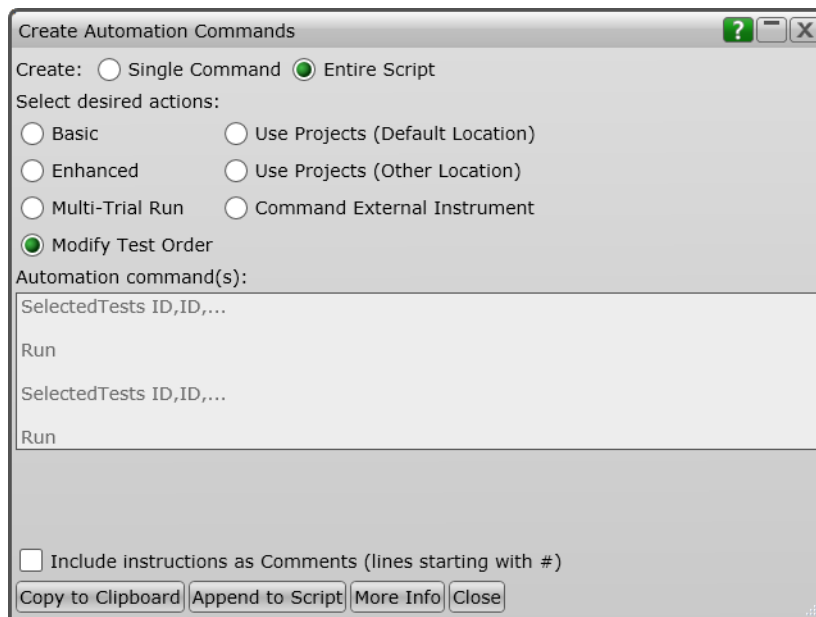

Once you have found the command or script you want, you may copy it to the clipboard or automatically append it to the script in the Automation tab. You may optionally include instructions to guide you in customizing the commands:

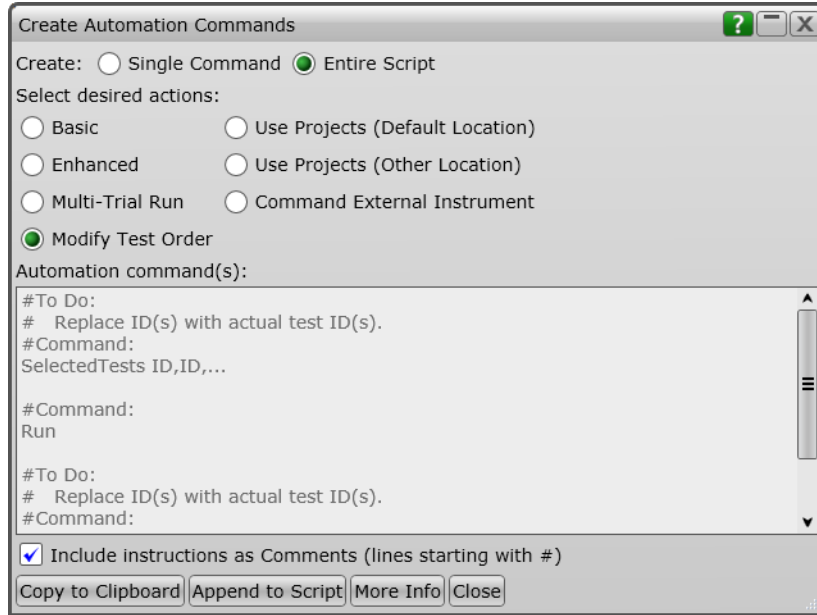

NOTE In the Automation tab script, lines starting with the pound symbol (#) do not execute.

See Also · ["To begin Script or Files execution"](#) on page 51

To enter commands in Files mode

In Files mode, the application will execute the commands it finds in the files shown in the list. The list is constructed and managed via the buttons on the left:

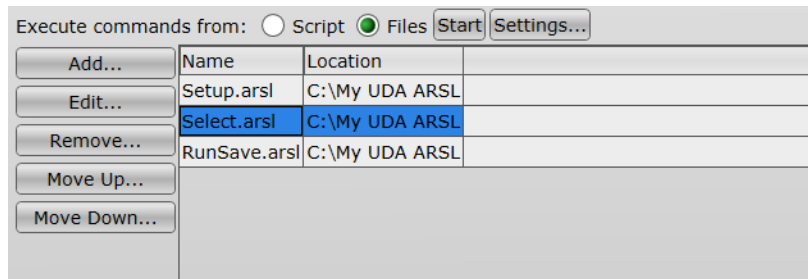

See Also · ["To begin Script or Files execution"](#) on page 51

To begin Script or Files execution

Click **Start** to begin Script or Files execution:

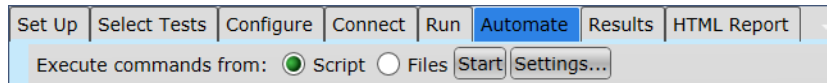

Before the first test executes, you may abort by clicking the same button (now labeled **Stop**) again.

To display automation settings status

Some commands will make visible changes to the application's tabs, such as selecting a test. Other commands only modify invisible settings, such as "SuppressMessages". The Automation Settings status dialog box displays the current value of the invisible properties:

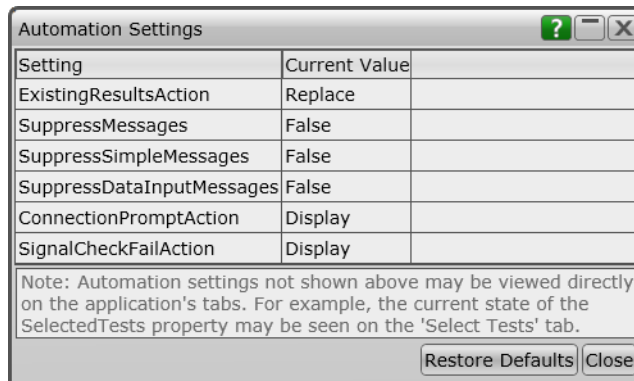
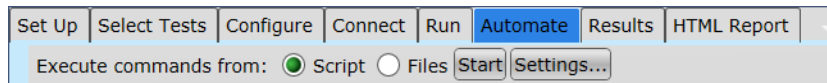

To try a command line

To experiment with a command, type it in the **Try a command** field and press <Enter> to execute it. If it has a visible effect, such as selecting a test, you may then go to another tab to see if it behaved as expected.

2 Using the Test Application

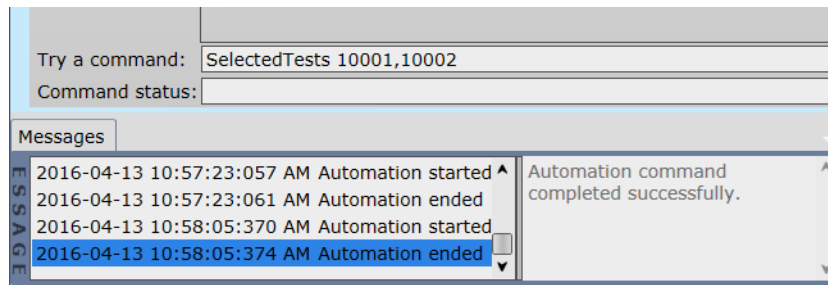

Viewing Results

- 1 Click the **Results** tab.

The screenshot displays the 'NFC Test Application -- NFC Device 1' window. The 'Results' tab is active, showing a list of test results. The following table represents the data shown in the main results pane:

Test Name	Actual Value	Margin %	Pass/Fail
✓ Listener: NFC-B, Parameter: Response Data	0000010101011111101101001101010010011101	100.0	Pa
✗ Poller: NFC-A, Parameter: Vov	-1.000 V	-15.8	Pa
✗ Poller: NFC-A, Parameter: Fc	-1 Hz	-678E+02	Pa
✓ Poller: NFC-A, Parameter: Overshoot	-1.0000 V	100E+02	Pa
✗ Poller: NFC-A, Parameter: Response Data	-	-100.0	Pa
ⓘ Poller: NFC-A, Parameter: Number of capture attempts	10		Pa
✓ Poller: NFC-B, Parameter: Vov	1.470 V	10.2	Pa
✓ Poller: NFC-B, Parameter: Fc	13.500 MHz	100.0	Pa

The lower right pane provides a detailed view of the selected test (Poller: NFC-A, Parameter: Vov). It includes a 'Trial Summary' table and a 'Messages' pane.

Trial Summary	Actual Value	Margin	PassLimit Min (LIMM)	Parameter	Value
Completed: 3	Mean -1.000 V	-15.79 %	500.0 mV	Poller: NFC-A, Parameter: Vov	-1.000 V
Passed: 0	StdDev 0.000 V	275.3 n%	0.000 V	---Additional Info---	
Failed: 3	Range 0.000 V	0.000 %	0.000 V	PassLimit Min (LIM_MANF_PollerA_Vov_MIN)	500 mV
Worst: 3	Min -1.000 V	-15.79 %	500.0 mV		
Max Displayed: 1	Max -1.000 V	-15.79 %	500.0 mV		
	Sum -3.000 V	-47.37 %	1.500 V		
	Trial 3 -1.000 V	-15.8%	500 mV		

The Messages pane shows the following log entries:

- 2016-04-13 03:29:24:982 PM Test Aborted
- 2016-04-13 03:29:54:076 PM Test Aborted
- 2016-04-13 03:29:54:185 PM Project Saving
- 2016-04-13 03:29:54:357 PM Project Saved
- 2016-04-13 03:29:54:575 PM Run ended
- 2016-04-13 03:29:54:591 PM Abort occurred

The status bar at the bottom indicates: (BETA VERSION) | Unsaved Changes | 65 Tests | Connection: NFC test w/TCI-II | **ABORT**

The Results tab contains three resizable panes for test results information. If you select one of the tests in the top pane, details are shown in the lower panes.

To delete results, right-click and choose to delete the results for the selected test or all tests.

Test Name	Actual Value
✓ Listener: NFC-A (Device off), Parameter: FDT	86.53 μ s
✓ Listener: NFC-A (Device off), Parameter: FDT	64 mV
✓ Listener: NFC-A (Device off), Parameter: FDT	10010000000000000010
✓ Listener: NFC-B (Device off), Parameter: FDT	202.47 μ s
✓ Listener: NFC-B (Device off), Parameter: LMA	57 mV

TIP

A quick way to reset all configuration options and delete all test results is to create a new project (see page 24). The new project will have default configuration options.

- See Also
- "To change margin thresholds" on page 54
 - "To set trial display preferences" on page 55
 - "To debug individual test failures with the oscilloscope" on page 57
- Next
- "Viewing/Exporting/Printing the Report" on page 59

To change margin thresholds

- 1 From the NFC Test Application's menu, choose **View > Preferences...**
- 2 In the Preferences dialog box, select the **Results** tab.

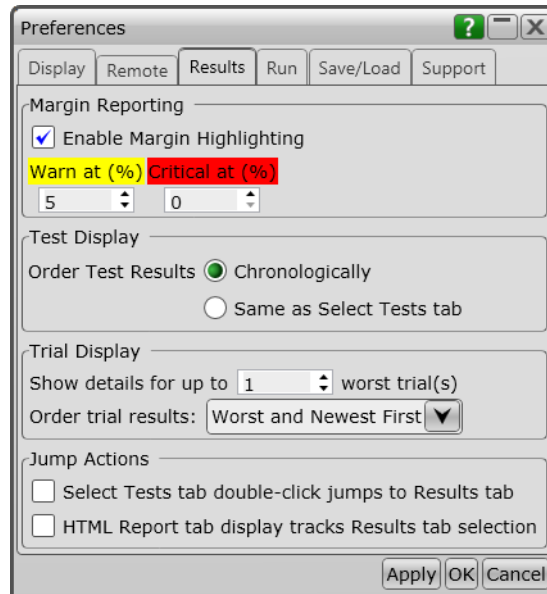

- 3 In the **Margin Reporting** area, you can:
 - Enable or disable margin highlighting.

- You can change the percent of margin at which to give warnings or critical failures.
- 4 Click **OK** to close the Preferences dialog box.

To set test display preferences

- 1 From the NFC Test Application's menu, choose **View > Preferences....**
- 2 In the Preferences dialog box, select the **Results** tab.

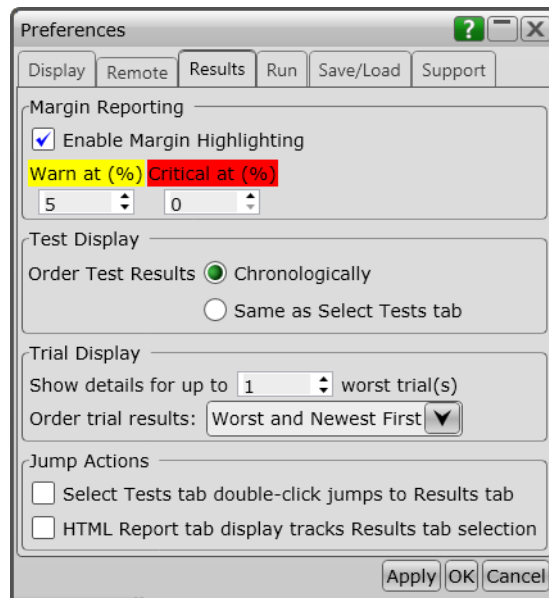

- 3 In the **Test Display** area, you can choose:
 - **Chronologically** – the test results table is arranged in the order of which test was run first.
 - **Same as Select Tests tab** – the test results table is arranged in the order seen in the test selection list.
- 4 Click **Apply** to save the changes and click **OK** to close the Preferences dialog box.

NOTE

These settings only affect the viewing of results and not their capture. Therefore, a change can be made to either before or after running the tests.

To set trial display preferences

- 1 From the NFC Test Application's menu, choose **View > Preferences....**
- 2 In the Preferences dialog box, select the **Results** tab.

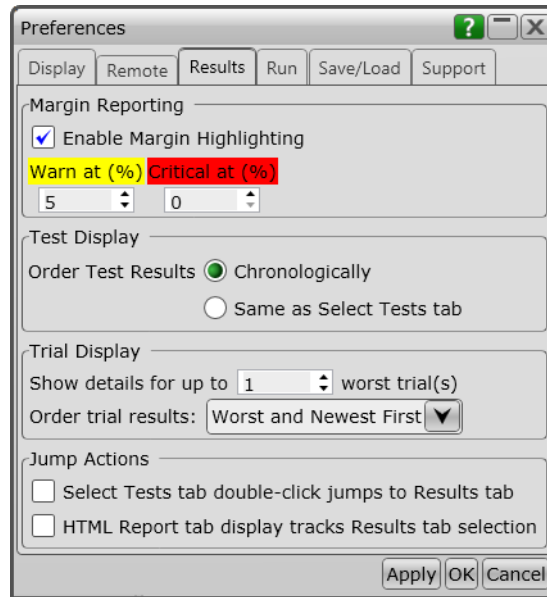

3 In the **Trial Display** area, you can:

- Select the maximum number of trials, up to 25, whose details are displayed at one time.
- Order trial details chronologically or by "best", "worst", or "last" trial first.
- Specify whether screens captured during the run are displayed in the Results tab.

Note that the "worst", "best", or "last" trials depends on the "store mode" setting in the Run tab. See **"To select the store mode"** on page 40.

4 Click **Apply** to save the changes and click **OK** to close the Preferences dialog box.

NOTE

These settings only affect the viewing of results and not their capture. Therefore, a change can be made to either before or after running the tests.

To select jump actions

- 1 From the NFC Test Application's menu, choose **View > Preferences....**
- 2 In the Preferences dialog box, select the **Results** tab.

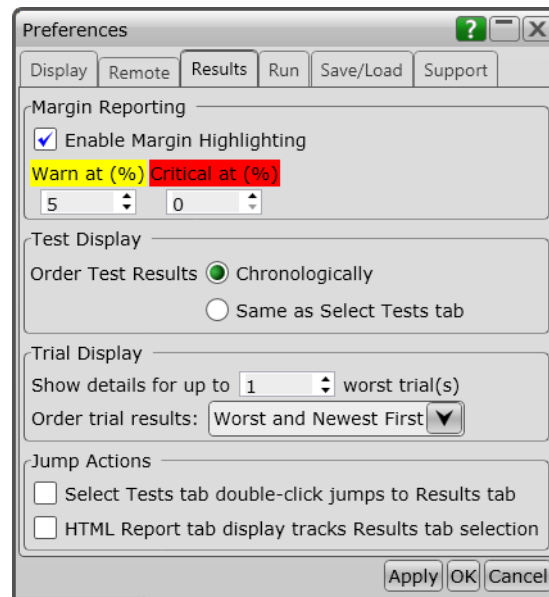

- 3 In the **Jump Actions** area, you can select:
 - **Select Tests tab double-click jumps to the Results tab** – when there are results for a test, double-clicking a test in the Select Tests tab goes to those results.
 - **HTML Report tab display tracks Results tab selection** – after selecting a test in the Results tab, clicking the HTML Report tab will display the report at the point where those test results appear.
- 4 Click **Apply** to save the changes and click **OK** to close the Preferences dialog box.

NOTE

These settings only affect the viewing of results and not their capture. Therefore, a change can be made to either before or after running the tests.

To debug individual test failures with the oscilloscope

Because the NFC test application license exists in the oscilloscope, you can easily shift from performing conformance tests with the application to debugging individual test failures with the oscilloscope. In this scenario, the application is useful for automatically setting up the equipment for a particular test. Then, you can go to the oscilloscope to look at the captured data in more detail.

For example, the following figure illustrates using the oscilloscope's NFC trigger mode to manually characterize the Poller NFC-B modulation depth after automated test failure.

2 Using the Test Application

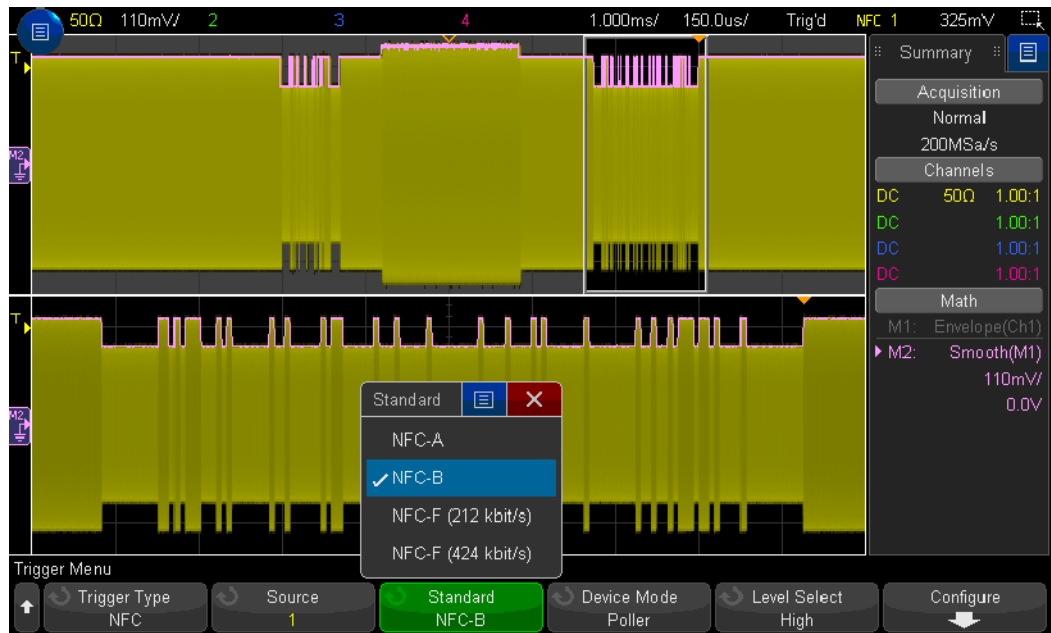

Viewing/Exporting/Printing the Report

- To view the HTML test report, click the **Html Report** tab.

The screenshot shows the 'NFC Test Application -- NFC Device 1' window. The 'HTML Report' tab is active, displaying the following content:

KEYSIGHT TECHNOLOGIES

Test Report

Overall Result: **FAIL**

Test Configuration Details	
Device Description	
Listener Type	Listener-3
Poller Type	Poller-3
Fixture Type	TCI-II
Test Session Details	
InfiniVision SW Version	04.07.2016040702
InfiniVision Model Number	MSO-X 3054T
InfiniVision Serial Number	MY54220110
Application SW Version	1.01.9032
Debug Mode Used	No
Last Test Date	2016-04-13 15:08:24 UTC -06:00

Summary of Results

Messages

- 2016-04-13 03:08:28:741 PM Test Aborted
- 2016-04-13 03:08:28:866 PM Project Saving
- 2016-04-13 03:08:28:991 PM Project Saved
- 2016-04-13 03:08:29:038 PM Run ended
- 2016-04-13 03:08:29:053 PM Abort occurred
- 2016-04-13 03:11:06:454 PM Discard Unsaved Changes?

Unsaved changes exist. Click OK to discard them and close; click Cancel to keep the dialog open [Response: Cancel (OKCancel)]

(BETA VERSION) | Unsaved Changes | 43 Tests | Connection: NFC test w/TCI-II | **ABORT**

The NFC Test Application provides complete report generation with statistical and margin analysis capabilities. NFC test results shows Poller/Listener parameters that fail to meet specifications highlighted in red, as well as marginal test results highlighted in yellow.

2 Using the Test Application

NFC Test Application -- NFC Device 1

File View Help

Set Up | Select Tests | Configure | Connect | Run | Automate | Results | **HTML Report**

Summary of Results

Test Statistics

Failed	3
Passed	31
Total	34

Margin Thresholds

Warning	< 5 %
Critical	< 0 %

HTML REPORT

Pass	# Failed	# Trials	Test Name	Actual Value	Margin	Pass Limits
✓	0	1	Listener: NFC-A, Parameter: FDT	86.54 μs	34.6 %	Pass if the DUT works in NFC-A Listener mode.
✓	0	1	Listener: NFC-A, Parameter: LMA	63 mV	21.3 %	Pass if the DUT works in NFC-A Listener mode.
✓	0	1	Listener: NFC-A, Parameter: Response Data	10010000000000000010	100.0 %	Pass if the DUT works in NFC-A Listener mode.
✓	0	1	Listener: NFC-B, Parameter: FDT	198.59 μs	21.7 %	Pass if the DUT works in NFC-B Listener mode.
✓	0	1	Listener: NFC-B, Parameter: LMA	56 mV	30.0 %	Pass if the DUT works in NFC-B Listener mode.
✓	0	1	Listener: NFC-B, Parameter: Response Data	000001010101000101010000000110111000101	100.0 %	Pass if the DUT works in NFC-B Listener mode.
✗	1	1	Poller: NFC-A, Parameter: Vov	-1.000 V	-10.0 %	Pass if the DUT works in NFC-A Poller mode.
✗	1	1	Poller: NFC-A, Parameter: Fc	-1 Hz	-678E+02 %	Pass if the DUT works in NFC-A Poller mode.
✓	0	1	Poller: NFC-A, Parameter: Overshoot	-1.0000 V	100E+02 %	Pass if the DUT works in NFC-A Poller mode.
✗	1	1	Poller: NFC-A, Parameter: Response Data	-	-100.0 %	Pass if the DUT works in NFC-A Poller mode.
?	1	1	Poller: NFC-A, Parameter: Number of capture attempts			Pass if the DUT works in NFC-A Poller mode.

Messages

2016-04-13 03:08:28:741 PM Test Aborted

2016-04-13 03:08:28:866 PM Project Saving

2016-04-13 03:08:28:991 PM Project Saved

2016-04-13 03:08:29:038 PM Run ended

2016-04-13 03:08:29:053 PM Abort occurred

2016-04-13 03:11:06:454 PM Discard Unsaved Changes?

Unsaved changes exist. Click OK to discard them and close; click Cancel to keep the dialog open [Response: Cancel (OKCancel)]

(BETA VERSION) | Unsaved Changes | 43 Tests | Connection: NFC test w/TCI-II | **ABORT**

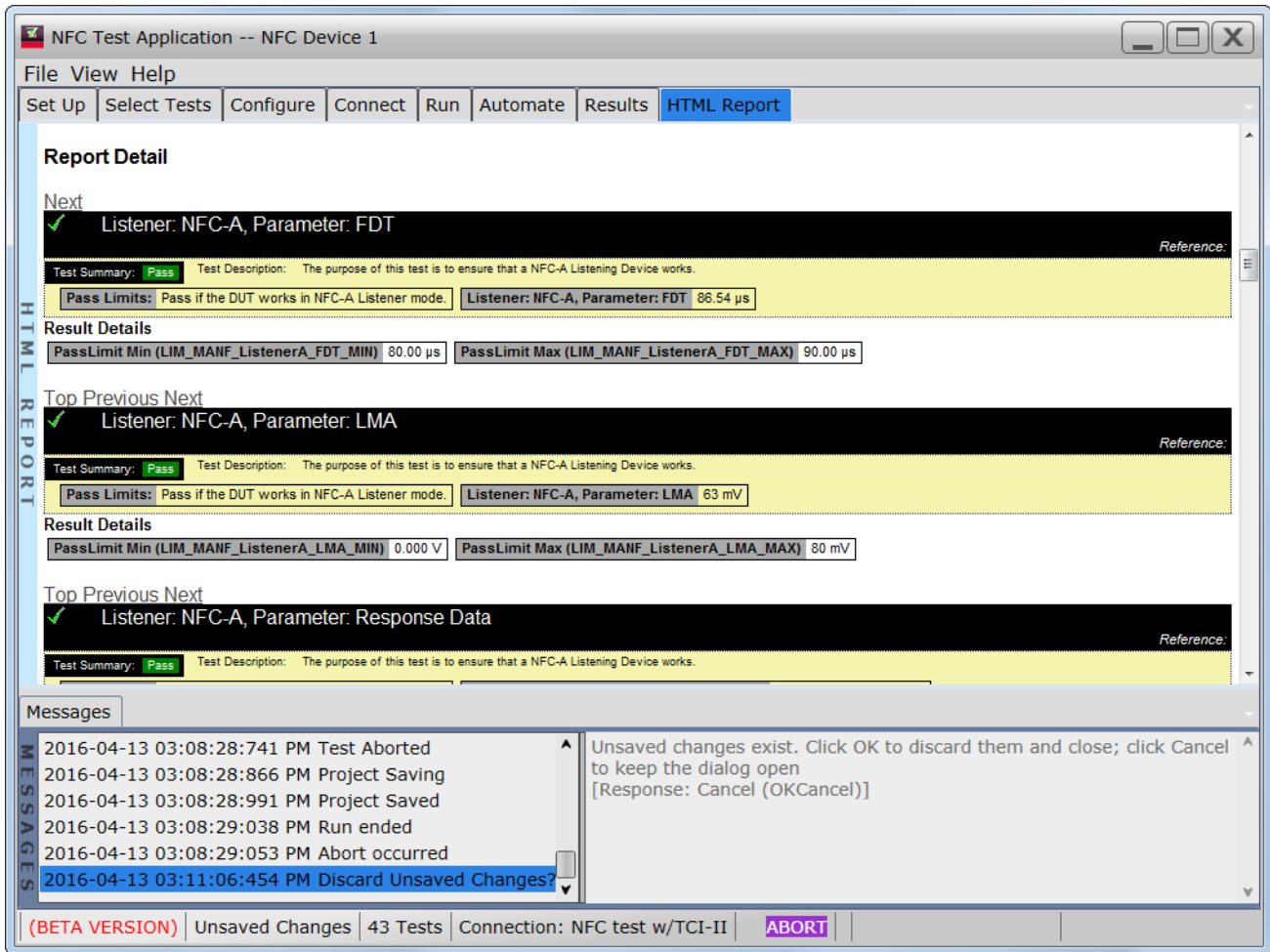

- See Also
- ["To export the report"](#) on page 61
 - ["To print the report"](#) on page 63
- Next
- ["Saving Test Projects"](#) on page 64

To export the report

- 1 From the NFC test application's menu, choose **File > Export Results >** from the menu.

There are two options for exporting the HTML test report: CSV or HTML.

To export results
in CSV
(comma-separated
values) format

Select the CSV option to export the results as a comma-separated list of values.

2 Using the Test Application

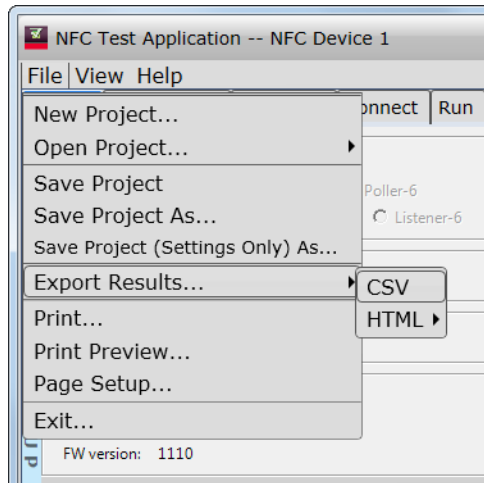

The data format is shown in the first line of the exported *.csv file.

```
Test ID, Test Name, Measured Item, Trial 1 value, Trial 2 value, Trial 3 value
10001,"Listener: NFC-A, Parameter: FDT",PassLimit Min (LIM_MANF_ListenerA_FDT_MIN),"8E-05","8E-05","8E-05"
10001,"Listener: NFC-A, Parameter: FDT",PassLimit Max (LIM_MANF_ListenerA_FDT_MAX),"9E-05","9E-05","9E-05"
10001,"Listener: NFC-A, Parameter: FDT",Actual Value,"8.654E-05","8.656E-05","8.657E-05"
10001,"Listener: NFC-A, Parameter: FDT",Margin,"34.6","34.4","34.3"
10002,"Listener: NFC-A, Parameter: LMA",PassLimit Min (LIM_MANF_ListenerA_LMA_MIN),"0.000","0.000","0.000"
10002,"Listener: NFC-A, Parameter: LMA",PassLimit Max (LIM_MANF_ListenerA_LMA_MAX),"0.08","0.08","0.08"
10002,"Listener: NFC-A, Parameter: LMA",Actual Value,"0.062","0.064","0.065"
10002,"Listener: NFC-A, Parameter: LMA",Margin,"22.5","20.0","18.8"
10003,"Listener: NFC-A, Parameter: Response Data",Actual
Value,"10010000000000000010","10010000000000000010","10010000000000000010"
10003,"Listener: NFC-A, Parameter: Response Data",Margin,"100.0","100.0","100.0"
10101,"Listener: NFC-B, Parameter: FDT",PassLimit Min (LIM_MANF_ListenerB_FDT_MIN),"0.00017","0.00017","0.00017"
10101,"Listener: NFC-B, Parameter: FDT",PassLimit Max (LIM_MANF_ListenerB_FDT_MAX),"0.000302","0.000302","0.000302"
10101,"Listener: NFC-B, Parameter: FDT",Actual Value,"0.00020213","0.00020102","0.0002049"
10101,"Listener: NFC-B, Parameter: FDT",Margin,"24.3","23.5","26.4"
10102,"Listener: NFC-B, Parameter: LMA",PassLimit Min (LIM_MANF_ListenerB_LMA_MIN),"0.000","0.000","0.000"
10102,"Listener: NFC-B, Parameter: LMA",PassLimit Max (LIM_MANF_ListenerB_LMA_MAX),"0.08","0.08","0.08"
10102,"Listener: NFC-B, Parameter: LMA",Actual Value,"0.056","0.057","0.057"
10102,"Listener: NFC-B, Parameter: LMA",Margin,"30.0","28.8","28.8"
10103,"Listener: NFC-B, Parameter: Response Data",Actual
Value,"00000101011100111000010010100110001","0000010101000011010101010111110110011101","000001010101111101101101
001101010010011101"
10103,"Listener: NFC-B, Parameter: Response Data",Margin,"100.0","100.0","100.0"
20002,"Poller: NFC-A, Parameter: Vov",PassLimit Min (LIM_MANF_PollerA_Vov_MIN),"0.5","0.5","0.5"
20002,"Poller: NFC-A, Parameter: Vov",Actual Value,"-1.000","-1.000","-1.000"
20002,"Poller: NFC-A, Parameter: Vov",Margin,"-15.8","-15.8","-15.8"
20003,"Poller: NFC-A, Parameter: Fc",Actual Value,"-1","-1","-1"
20003,"Poller: NFC-A, Parameter: Fc",Margin,"-67750.0","-67750.0","-67750.0"
```

To export the report in HTML format

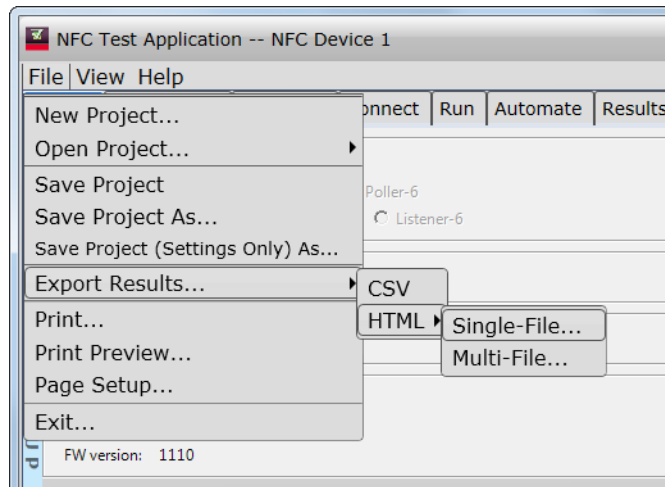

There are two options for exporting HTML format test reports:

- **Single-File** – To save a single-file report, use the "save as" type "Web Archive, single file (.mht)".

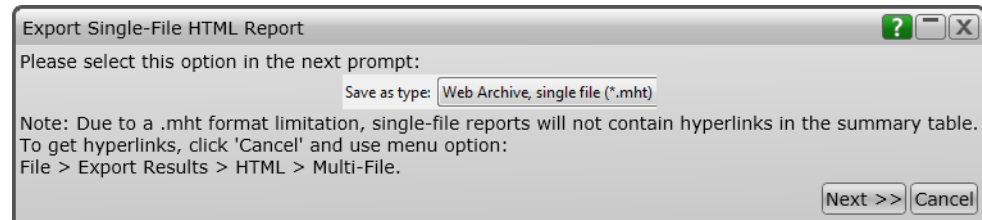

NOTE

Single-file reports will not contain hyperlinks in the summary table (due to a .mht format limitation). If you want these hyperlinks, use the multi-file format.

- **Multi-File** – If your report is large and you would like to use links within the report, select the **HTML > Multi-File** option. Selecting the multi-file option exports the results as a set of separate image and HTML files. It creates a folder with the specified name that may be copied to any computer.

To view the exported report, open the HTML file stored in the folder.

To print the report

- To preview the HTML test report printout, choose **File > Print Preview...** from the menu.
- To print the HTML test report, choose **File > Print...** from the menu.

Saving Test Projects

To save test settings and results to the current project directory:

- 1 Choose **File > Save Project** from the menu.

To save test settings and results to a new project directory:

- 1 Choose **File > Save Project As...** from the menu.

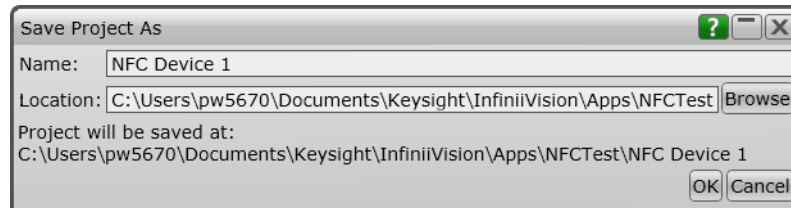

- 2 In the Save Project As dialog box, enter the device name and location. Project files will be saved in a directory whose name is the device name.
- 3 Click **OK**.

See Also · ["To set AutoRecovery preferences"](#) on page 64

To set AutoRecovery preferences

- 1 From the NFC test application's menu, choose **View > Preferences...**
- 2 In the Preferences dialog box, select the **Save/Load** tab.

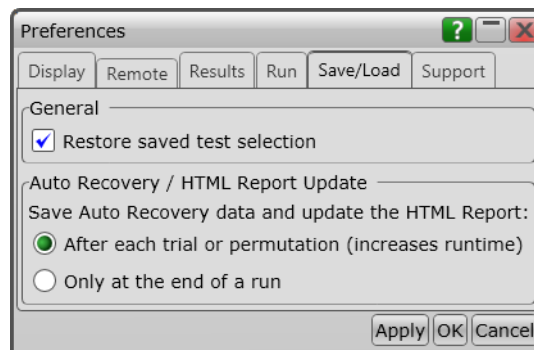

- 3 In the **AutoRecovery** area, you can choose:
 - To auto-save results after each trial or permutation even if the entire multi-trial is not completed. This option enables full recovery.
 - To auto-save results only upon the completion of the entire multi-trial.
- 4 Click **Apply** to save the changes and click **OK** to close the Preferences dialog box.

Controlling the Application via a Remote PC

The NFC test application's Preference dialog box has a **Remote** tab for enabling the remote interface and setting remote options.

The remote interface lets you control test applications from a remote PC. It comes with ready to run executables, but it also lets you create custom programs using a .NET 2.0 programming language or the National Instruments' LabVIEW 8.5 graphical programming environment.

With the remote interface, you can:

- Launch and close applications.
- Configure options.
- Run tests.
- Obtain results.
- Control when and where dialog boxes are displayed.
- Save and load projects.

For more information on the remote interface, see the [N5452A Remote Interface for Infiniium Compliance Applications](#) on the Keysight web site.

- See Also**
- ["To identify the remote interface version"](#) on page 65
 - ["To enable the remote interface"](#) on page 66
 - ["To enable remote interface hints"](#) on page 67

To identify the remote interface version

- 1 From the NFC test application's menu, choose **Help > About...**
- 2 In the About dialog box, the remote interface version is listed above other version information.

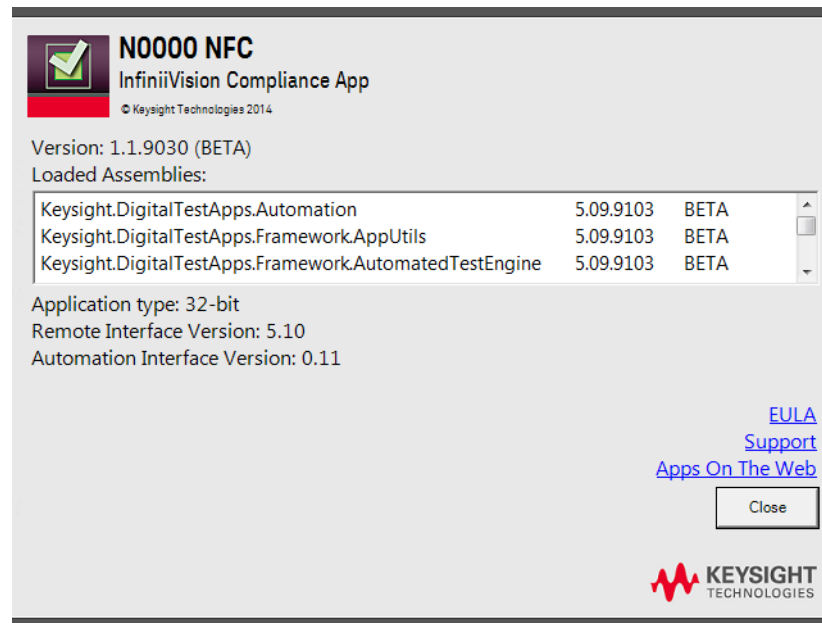

To enable the remote interface

- 1 From the NFC test application's menu, choose **View > Preferences...**
- 2 In the Preferences dialog box, select the **Remote** tab.

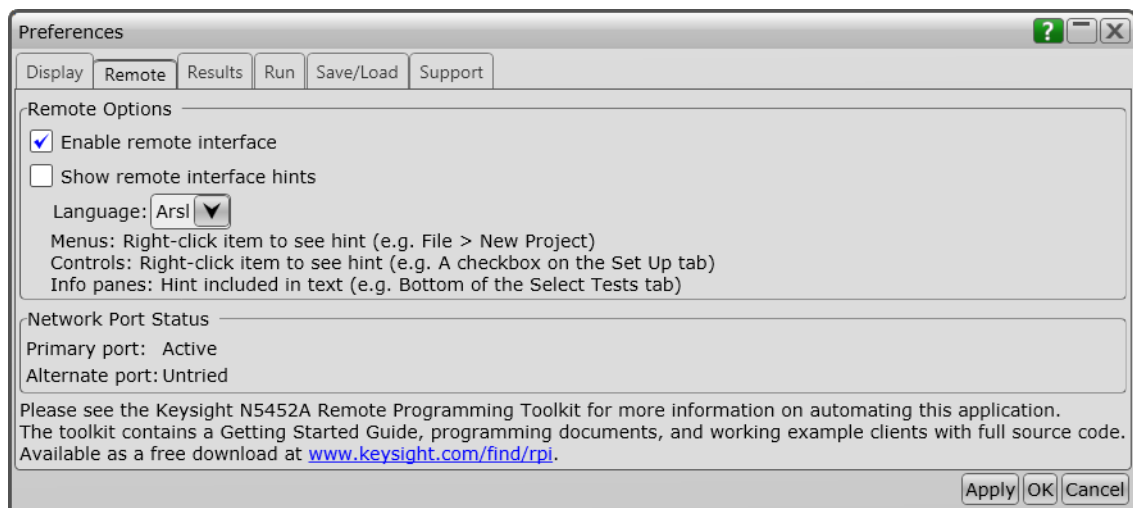

- 3 Check the **Enable remote interface** option if you need to access the application remotely.

If you are performing the tests with the application's user interface and want to ensure no remote users accidentally interfere with you, disable the remote interface by un-checking this option.

- 4 Click **Apply** to save the changes and click **OK** to close the Preferences dialog box.

To enable remote interface hints

- 1 From the NFC test application's menu, choose **View > Preferences...**
- 2 In the Preferences dialog box, select the **Remote** tab.



- 3 In the remote options area, check **Show remote interface hints**.

When this option is checked:

- You can select the remote programming language described in the tips.
 - Tooltips related to the remote interface commands appear when you click the toolbar.
 - Various controls in the tabs will have a context menu item added as "Remote interface hint...".
 - The **Select Tests** and **Configure** tabs will display a remote hint in their description panes at the bottom of the screen, when an item is selected.
- 4 Click **Apply** to save the changes and click **OK** to close the Preferences dialog box.

2 Using the Test Application

3 About the Tests

Keysight's automated NFC test software provides higher-level functional pass/fail testing, as well as lower-level physical layer parametric testing. You have the ability to customize your specific test needs by selecting just the measurements required for your particular test environment. The following table shows the measurements that can be selected.

Table 1 Keysight NFC Test Coverage

Test	NFC-A	NFC-B	NFC-F (212 kbps)	NFC-F (424 kbps)
Listener Mode Tests				
Pass/Fail	√	√	√	√
Frame delay time (FTD)	√	√	√	√
Load modulation amplitude (LMA)	√	√	√	√
Response data	√	√	√	√
Poller Mode Tests				
Pass/Fail	√	√	√	√
t_1	√			
t_2	√			
t_3	√			
t_4	√			
t_5	√			
Data rate	√	√	√	√
Field strength (V_{ov})	√	√	√	√
Carrier frequency (F_c)	√	√	√	√
Modulation depth	√	√	√	√
Modulation index	√	√	√	√
Response data	√	√	√	√
Overshoot	√	√	√	√
Undershoot		√	√	√
Rise time (t_r)		√	√	√
Fall time (t_f)		√	√	√
Resonant Frequency Test (F_r)	√			

Resonant Frequency Test (F_r) with the Keysight 3-in-1 Antenna

If you want to run the Resonant Frequency Test (F_r) with the Keysight 3-in-1 antenna, the F_r channel needs to be changed from Channel 1 to Channel 4 or whichever channel the Listener tests use.

Disable NFC before running the F_r test; otherwise, the device under test may decide to start talking in the middle of the F_r test which will affect the results.

While there will be less drop when using the same test position setup as for Listener and Poller tests (at 15 mm) than using the ideal F_r test position, the signal should still be clear and present.

4 Manufacturing Mode Integration

NOTE

Please ensure that the NFC test application is installed before proceeding with this section.

In addition to the normal graphical user interface (GUI) presented by the NFC application, there is another mode, known as Manufacturing Mode, where the application can be invoked without the GUI showing. This mode provides faster runtime and is intended for manufacturing environments where test execution speed is critical and the GUI is not required.

Manufacturing Mode is similar to the remote interface (see "[Controlling the Application via a Remote PC](#)" on page 65) in that you can automate the application from a program, but it also lets you automate multiple instances of the application on the same PC (which the remote interface does not allow).

By default, the application's Manufacturing Mode provides integration with test systems in these environments:

- C#
- native C++
- C++/CLI

The *Keysight DigitalTestApps Automation Interface Programmer's Reference* describes the available interfaces to interact with the application in Manufacturing Mode. This programmer's reference also contains many examples that show you how to use the automation interface. You can view this documentation from the NFC test application by choosing **Help > Automation > Contents**.

All headers and libraries required to integrate the manufacturing mode is located in the app installation directory. Below is the default path for app installation:

- 32-bit systems: C:\Program Files\Keysight\InfiniiVision\Apps\NFCTest
- 64-bit systems: C:\Program Files (x86)\Keysight\InfiniiVision\Apps\NFCTest

Steps to integrate and run the application through the manufacturing interface:

C#:

- Include the Keysight.DigitalTestApps.Automation.dll into the list of references.

C++, C++/CLI:

- Copy the Keysight.DigitalTestApps.Automation.NativeCppAdapter.h and Keysight.DigitalTestApps.Automation.NativeCppAdapter.lib into your project folder. Include Keysight.DigitalTestApps.Automation.NativeCppAdapter.lib into the list of libraries.
- Copy the Keysight.DigitalTestApps.Automation.NativeCppAdapter.dll file into the same directory as your compiled .exe.

In order to select tests, you must provide the test ID as an argument to this manufacturing mode interface. The test ID can be obtained from the remote programmer's reference included with the application.

Index

Symbols

.NET Framework 4.5.2, 14

Numerics

3000T X-Series oscilloscope, 8
3-in-1 port for Keysight 3-in-1 antenna, 27
4000 X-Series oscilloscope, 8

A

antenna type, 25
automation interface example programs, 73
automation interface programmer's reference, 73
automation interface vs. remote interface, 73
Automation tab, 48
automation variable name, 32
AutoRecovery preferences, 64

B

beep only during run, 47
beep when user prompted, 47
best trials, store mode, 41
block diagram, Keysight 3-in-1 programmable NFC antenna, 9
block diagram, Keysight TCI-II programmable NFC antenna, 12

C

chronological test display, 55
color scheme, 46
command line (Automation), trying, 51
comma-separated value (CSV) format, export results, 61
configuring tests, 31
configuring variable description, 31
connecting test equipment, 33
Connection Expert, 16
connections, Keysight 3-in-1 antenna, 34
connections, reference poller antenna, 36, 37
connections, TCI-II antenna, 35
controller PC requirements, 9

copyright, 2
creating test project, 24
critical at percent of margin, 54
CSV (comma-separated value) format, export results, 61

D

dimensions, N2116A 3-in-1 programmable NFC antenna, 10
dimensions, N2134A 3-in-1 programmable NFC antenna, 11
dimensions, N2135A 3-in-1 programmable NFC antenna, 12
display preferences, 45
DSOX4NFC license (oscilloscope), 15
DSOXT3NFC license (oscilloscope), 15

E

email on pause or stop, 43
enable margin reporting, 54
enable remote interface, 66
Entire Script creation, Automation, 49
Entitlement Certificate, 15
environment (test), setting up, 25
equipment (test), connecting, 33
equipment required, 8
error dialog boxes, 46
event specification, 45
event trials, store mode, 41
events, pause or stop on, 43
execution (Automation), starting, 51
exporting the report, 61

F

fail event, 45
failures (test), debugging with oscilloscope, 57
Files mode Automation, 50
forever, run until setting, 42

H

hints, remote interface, 67
HTML format, export results, 63

HTML test report, viewing/exporting/printing, 59

I

I/O libraries, 9, 14
information dialog boxes, 46
invert scope display, 46

J

jump actions, 56

K

keep application on top, 46
Keysight 3-in-1 antenna, connections, 34
Keysight 3-in-1 programmable NFC antenna, 8, 9
Keysight Connection Expert, 16
Keysight I/O libraries, 9, 14
Keysight Interactive IO application, 19
Keysight IO Control icon, 16
Keysight TCI-II programmable NFC antenna, 8, 12
Keysight_3-in-1 antenna type, 25

L

LAN instrument, 18
LAN interface, 16
last trials, store mode, 41
license (oscilloscope), NFC triggering, 15
listener reference NFC antennas, 8
load preferences, 24

M

manufacturing mode integration, 73
margin < N event, 45
margin thresholds, changing, 54
MATLAB Compiler Runtime 7.15, 14
multi-file HTML, export results, 63
multiple runs, 41

N

N times, run until setting, 42
 N2116A 3-in-1 programmable NFC antenna,
 5 mm spacing, 8
 N2134A 3-in-1 programmable NFC antenna,
 10 mm spacing, 8
 N2135A 3-in-1 programmable NFC antenna,
 15 mm spacing, 8
 N5452A remote interface, 65
 NFC antenna required, 8
 NFC physical layer conformance testing, 3
 NFC test application software, 14
 NFC test application, using, 21
 notices, 2

O

once, run until setting, 42
 opening test project, 24
 oscilloscope address, 26
 oscilloscope licenses, installing, 15
 oscilloscope required, 8
 oscilloscope, debugging individual test
 failures with, 57

P

pass event, 45
 pause on event, 43
 pause, email on, 43
 PC requirements, 9
 poller reference NFC antennas, 8
 preferences, display, 45
 preferences, remote, 66
 preferences, report, 54, 55
 preferences, run, 47
 preferences, save/load, 24, 64
 prerequisites, 7
 preview print, 63
 printing HTML test report, 63
 project, creating or opening, 24
 project, saving, 64

R

reference antenna type, 25
 reference NFC antennas, 8
 reference poller antenna, connections, 36,
 37
 remote control, 65
 remote interface hints, 67
 remote interface version, 65
 remote interface vs. automation
 interface, 73
 remote interface, enable, 66
 remote preferences, 66

report (HTML),
 viewing/exporting/printing, 59
 report preferences, 54, 55
 report, exporting, 61
 report, printing, 63
 required equipment and software, 8
 requirements, controller PC, 9
 requirements, software, 9
 resonant frequency test with Keysight 3-in-1
 antenna, 70
 results, viewing test, 53
 run multiple times, 41
 run preferences, 47
 run until, 41
 running tests, 38

S

save/load preferences, 24, 64
 saving test project, 64
 Script mode Automation, 48
 Select Tests order for test display, 55
 selecting tests, 29
 set up test environment, 25
 show tooltips, 46
 Single Command creation, Automation, 49
 single-file HTML, export results, 63
 software required, 8
 software requirements, 9
 software, installing required, 14
 starting execution, Automation, 51
 starting NFC Test Application, 22
 status settings, Automation, 51
 stop on event, 43
 stop, email on, 43
 store mode, 40

T

tab layout, reset, 23
 TCI port for TCI-II antenna, 27
 TCI-II antenna type, 25
 TCI-II antenna, connections, 35
 test environment, setting up, 25
 test equipment, connecting, 33
 test failures, debugging with
 oscilloscope, 57
 test IDs for automation interface, 74
 test project, creating or opening, 24
 test project, saving, 64
 test report (HTML),
 viewing/exporting/printing, 59
 tests, about the, 69
 tests, chronological display, 55
 tests, configuring, 31
 tests, display in Select Tests order, 55
 tests, running, 38
 tests, selecting, 29
 tests, viewing results, 53
 tooltips, show, 46

trial display preferences, 55
 trials, best/worst/last, 40, 55
 trying a command line, Automation, 51

U

unavailable tests, 29

V

version, remote interface, 65
 viewing HTML test report, 59
 viewing test results, 53

W

warn at percent of margin, 54
 warning dialog boxes, 46
 warranty, 2
 waveform generator address, 26
 waveform generator required, 8
 worst trials, store mode, 41